

**CENTURY»»**

**CENTURY»»**

***2.8Tonne Electro-Hydraulic  
Four Post Parking Hoist  
RH-4TP-28***



**Century Equipment Distributors (NZ)**

E-mail: [sales@centurydistributors.co.nz](mailto:sales@centurydistributors.co.nz)

# Technical data

Model	RH-4TP-28
Lifting capacity	2800Kg
Lifting Height	3536mm
Min. Height	350mm
Lifting time	70-90 sec
Motor/Voltage	3Ph 400V 3.0KW 50/60Hz

\* All specifications subject to change without prior notice.

## RH-4TP-28

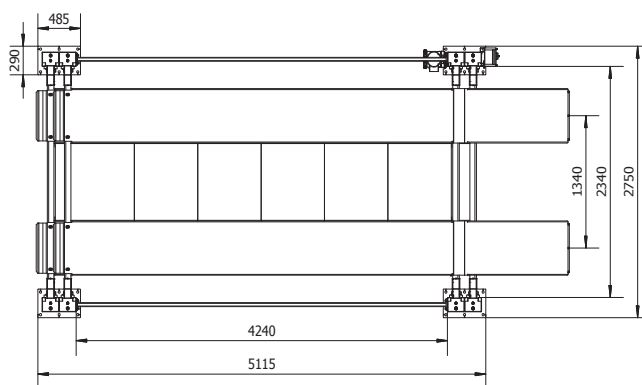
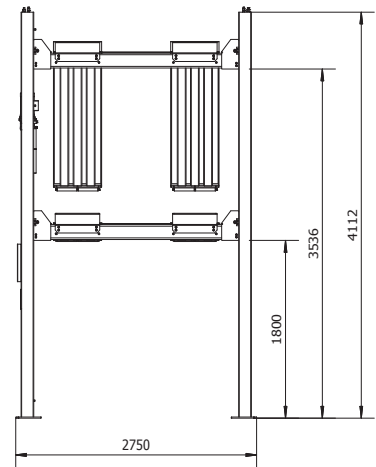
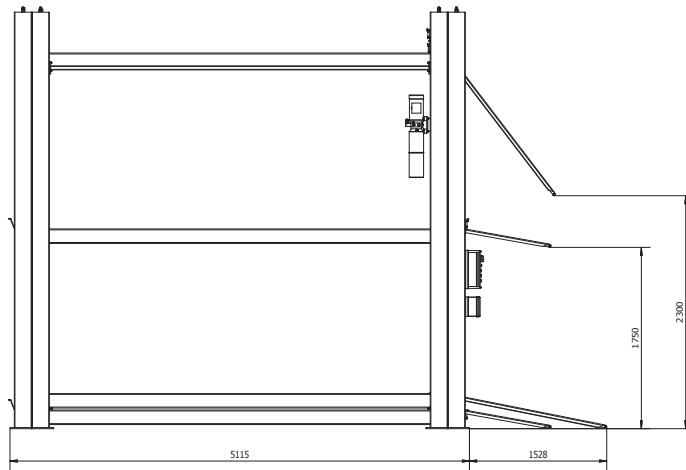

# RH-4TP-28

# CENTURY »

Century Equipment Distributors (NZ)

E-mail: [sales@centurydistributors.co.nz](mailto:sales@centurydistributors.co.nz)