

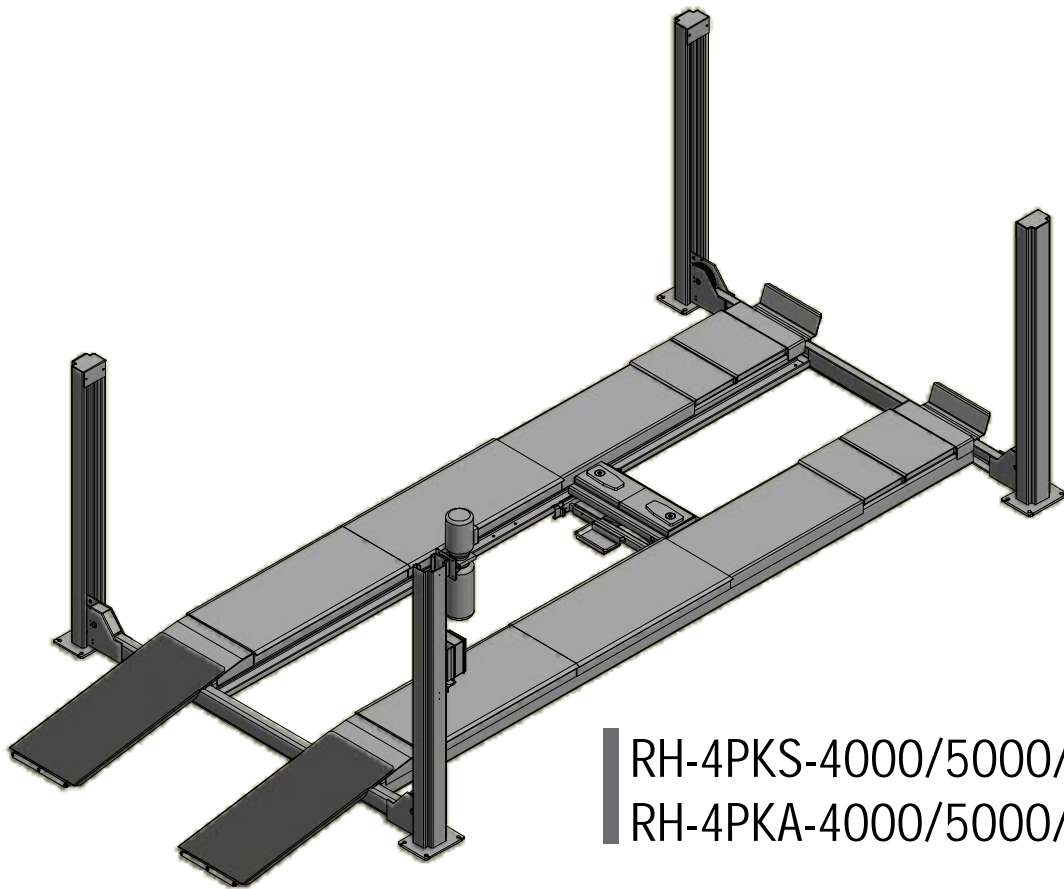

CENTURY 4 POST LIFT

(AIR-Hydraulic type jacking beam)

Installation Manual



RH-4PKS-4000/5000/6000

RH-4PKA-4000/5000/6000

Updated 10/03/2025

Please read this manual before you get started.

You must read and understand the precautions for safety purposes and any damages that may occur to your property.



CENTURY EQUIPMENT DISTRIBUTORS

54-68 WAINUI ROAD WAIWHETU
LOWER HUTT 5010 NEW ZEALAND

Tools Required:



Place all the components as shown to check supplied parts.



TRANSPORTATION AND INSTALLATION

Preparation for installation

The hoist shall be installed on hard and flat floor made with reinforced concrete at 32MPa grade with the thickness of 100mm minimum. The anchor bolt shall be M16 x 140mm tru-bolt and requires 16 anchor bolts.

Iccons Part No TB16140



Generally, this machine will be installed on the following conditions:

- 1) Supply voltage: 0.9 - 1.1 nominal supply voltage
- 2) Source frequency: 0.99 - 1.01 nominal frequency
- 3) Ambient temperature: 50C - 400C
- 4) Altitude: shall be at altitudes up to 1000m above mean sea level
- 5) Relative humidity: not exceed 50% at 40°C
- 6) Atmosphere: Free from excessive dust, acid fume, corrosive gases and salt.
- 7) Avoid exposing to direct sunlight or heat rays which can change the environmental temperature.
- 8) Avoid exposing to abnormal vibration.
- 9) Electrical equipment shall withstand the effects of transportation and storage temperature within a range of -25°C to 55°C and for short periods not exceeding 24 hours at up to +70°C.

*Please find the layout dimensions for the various models at the end of this manual

Installation Process

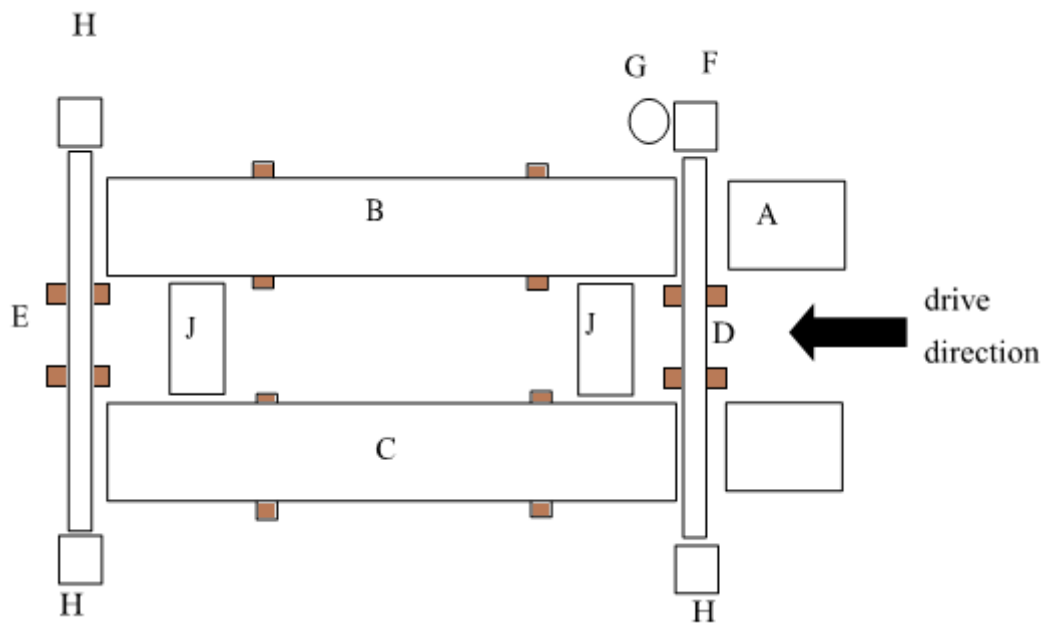

Layout Reference Diagram

- A - Run up ramps
- B - Control platform
- C - Non-control platform
- D - Transverse beam control end
- E - Transverse beam non-control end
- F - Control post
- G - Power pack
- H - Non-control post
- J - Jacking beam

Placing hoist on the installation location using timber under the platforms and transverse beams

- 1) Place the main parts on the appropriate position in reference to the above layout diagram.

Assembling Transverse Beam for Platforms

1. Take the pins fixing guide block, pull out the pins and take out the transverse beam pulleys (4 positions)

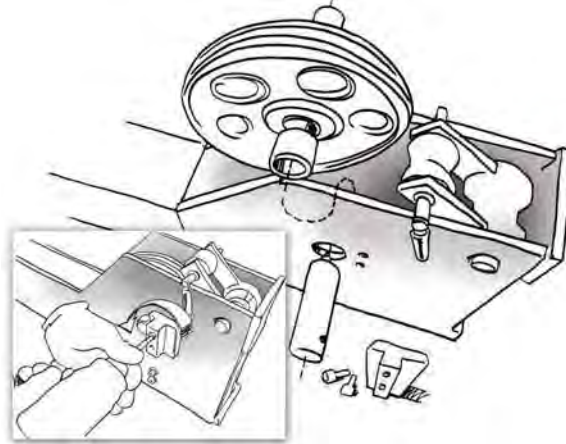

2. Remove the wood pieces inside the platform which are holding the cables inside. Cut the cable ties and pull out the large black conduit and tighten the nut to the side of the platform.

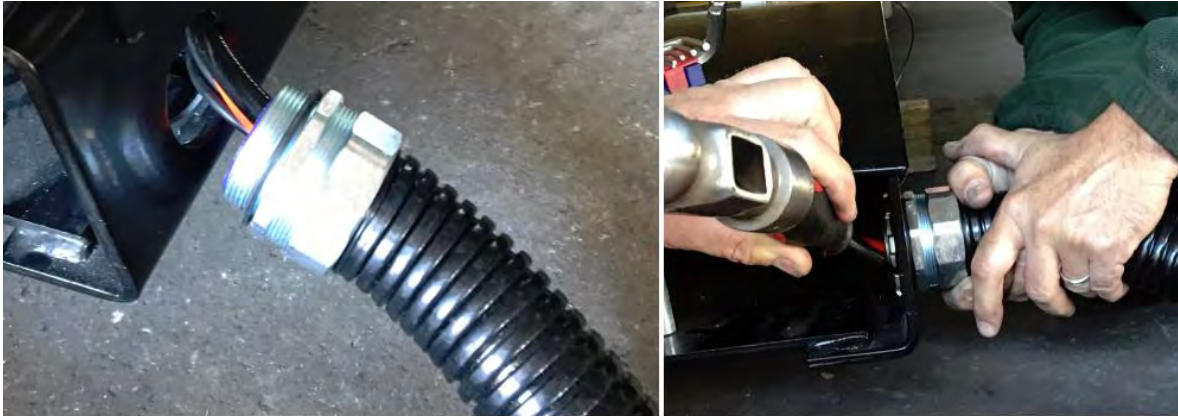

3. Connect the lock cables into each end of the transverse beams.



4. Take out the control platform cable and put it to the control end transverse beam. This is best done with 2 people, one at each end of the platform pulling out each cable (one in each hand).
Please ensure the cables are positioned correctly on the platform pulleys. (Refer to cable arrangement diagram at the back of this manual.)

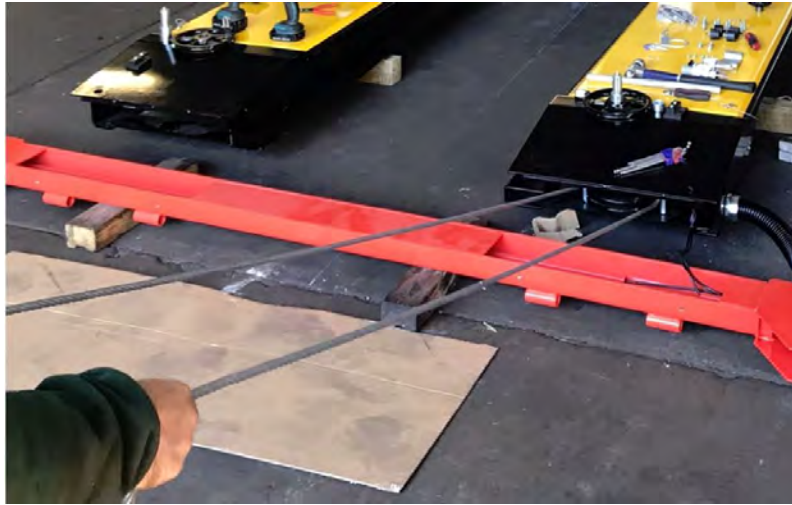

NOTE! Fix nuts on each end of the cables to protect the thread from damage

5. Starting with the non-control end transverse beam, bring the cables through the ends of the transverse beam and reassemble the pulleys in the reverse order that they were disassembled.

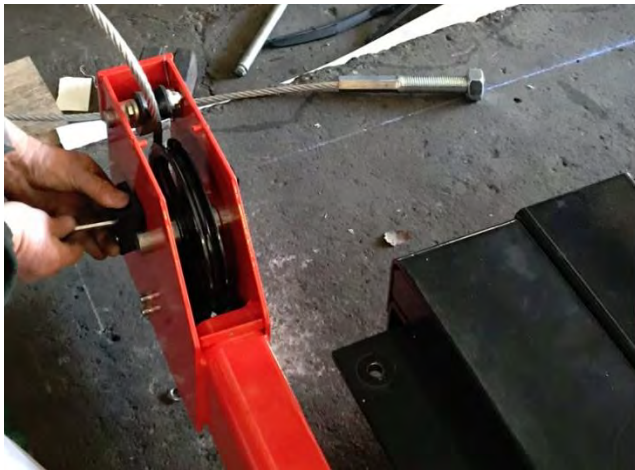

NOTE! 1) The Cable Arrangement Diagrams respectively on page 20 and 21 of this manual.
2) The pulley pins require greasing, further info on page 15 of this manual.

6. Attach the platforms to the non-control transverse beam.



7. Install the front wheel stop on each platform.



8. Moving to the control transverse beam, bring cables through the ends and reassemble the transverse beam pulleys.



9. Attach the rear of the platforms to the control transverse beam.



Assembling the Lock Rails and Posts

10. Square up the now assembled transverse beam and platform to ensure square and level.
11. Place the lock rails through the transverse beam ends and locate in the hole at the bottom of the posts.

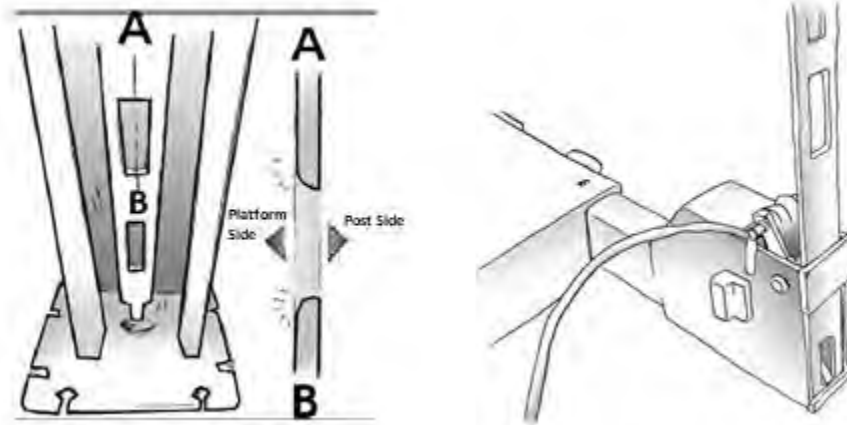

NOTE! When assembling the lock rail, place the round part of the rail holes facing away from the post.

NOTE! Check that the lock rail bottom is located in the hole on base plate/ bottom of post.

NOTE! Post with lock sticker should be placed as the front control side so easily visible at controls, as can be seen in the Figure below:



12. Before setting up the posts, put the lock rail fixing full-thread bolts to the top of the posts.
13. Put the bottom of the lock rail to the base hole as previously mentioned and set up the post.

14. Fasten:

- 2 (a) nuts (16mm) as shown in the figure below, fasten the upper nut clockwise and the lower nut counter clockwise, maintaining approx. space to the lock rail for 45-60mm (guideline only).
- 2 (b) nuts (11.5mm) each to opposite direction, maintaining 2-3 threads (3mm) between the nuts.
- Fix (c) nut tight to the lock rail.

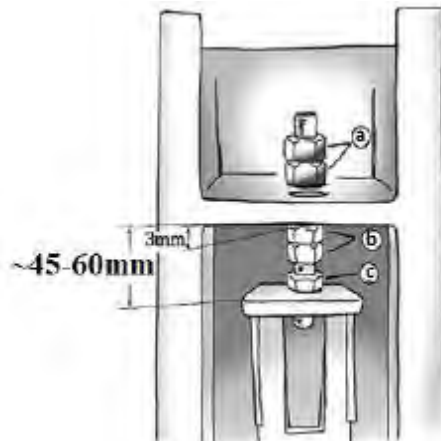

15. Set up the posts, maintaining the space of approx. 45-60mm between the fixing plate of the top of the post and the lock rail bracket.

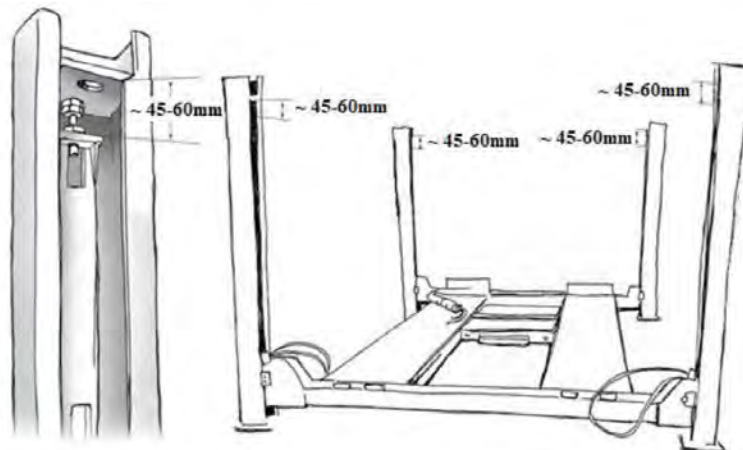

16. Shim the posts as required, drill concrete holes and install anchor bolts, fasten the nuts lightly.

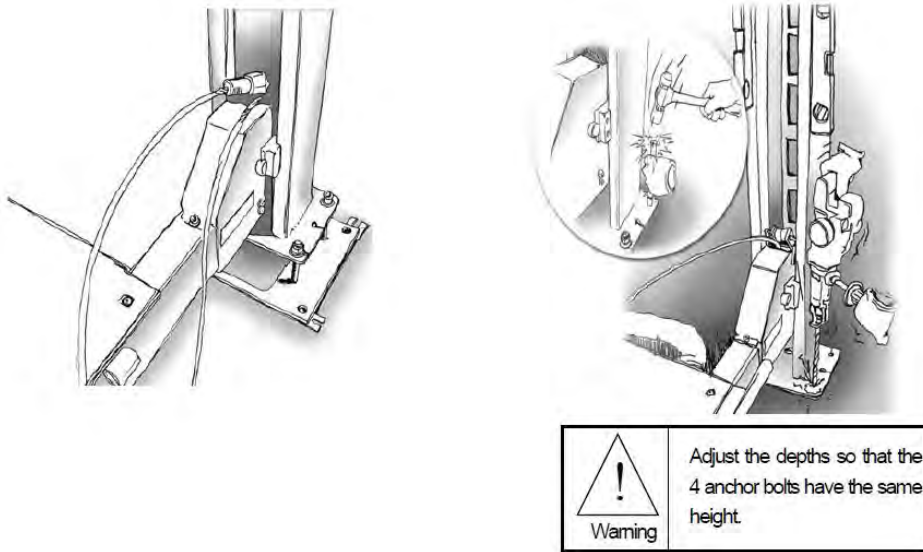

NOTE! Shim up baseplates so that posts are vertical. As much baseplate surface should be in contact with the floor as possible. Molnar recommends at least 50% surface to floor contact, especially in the middle of the baseplate which must be in contact with the floor or shimmed.

Post Base Plate for Leveling available

- Part Number 450-S-15 -> for 4PK-4000/5000
- Part Number 460-S-15 -> for 4PK-6000



- 17. Place the spirit level on the posts and using shims, adjust the posts to be vertical to the ground in all 4 posts.

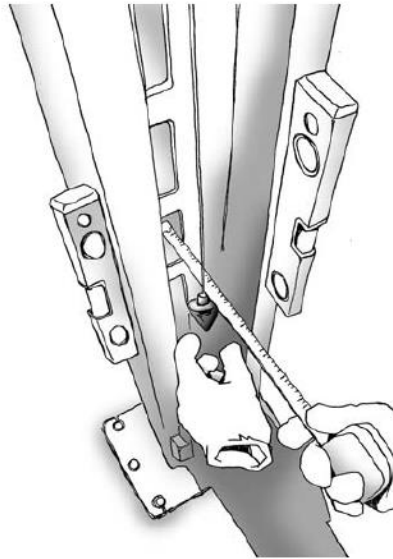

Set the posts so that guide blocks slightly contact and hold the posts when lifting up/down the platforms.

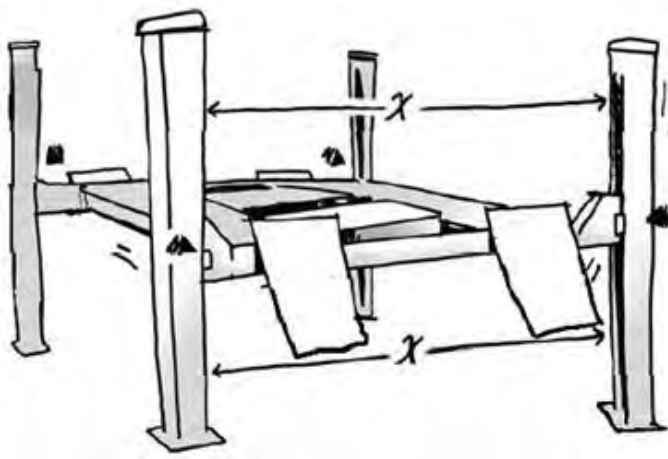

Adjust vertically and level the 4 posts and then tighten the anchor nuts. Raise the platform to the first or second lock position and recheck platform levels. Use a Spirit Level and Laser Level to ensure accurate leveling of the wheel alignment platforms, Shimming may be required to ensure accuracy.

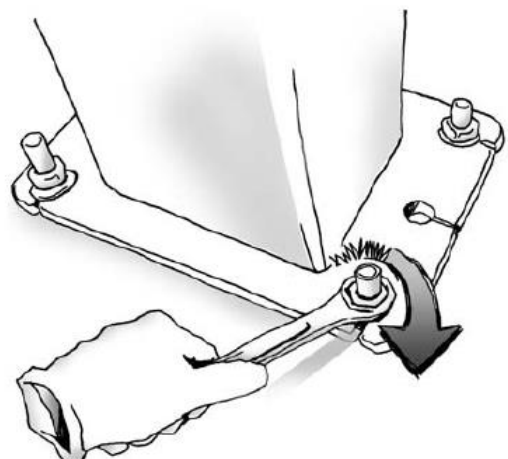
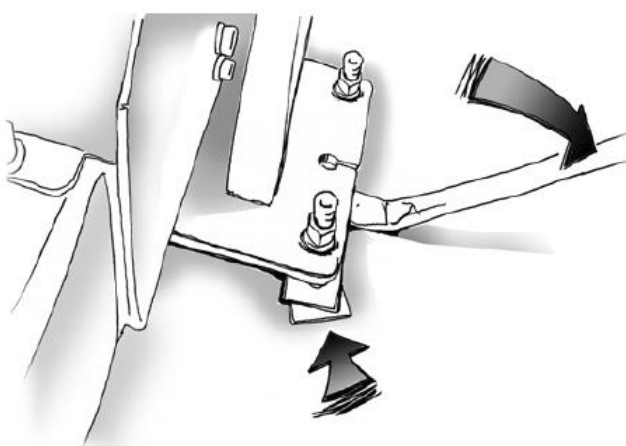

18. Attach the limit switch to the bracket and assemble to the lock rail as shown. Re-adjust the height as required on commissioning.

NOTE! Ensure the bracket is tightly fitted to lock rail and doesn't slide up or down. The roller lever can also be set at a downward angle when necessary.

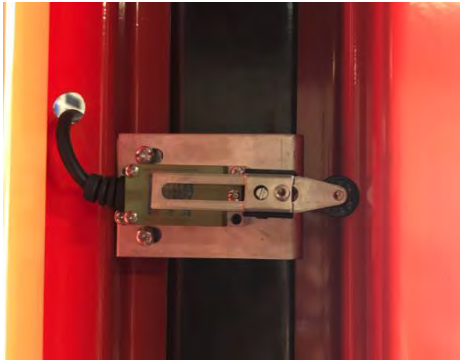

(Old Type)



(Current New Type)

19. Install the cable end through the hole in the top of the post plate and fasten both nuts together as shown below on top of the post plate.



20. Attach the conduit holder bracket, air regulator and control box to the post. Then attach the black conduit end to the holder bracket.

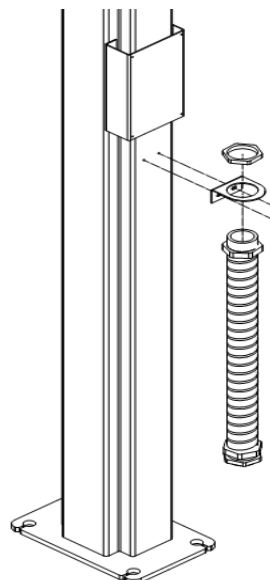

21. Mount the power pack mounting plate to the post. Attach the motor mount and rubber mounts to the power pack and attach to the post as shown in the image below. Remove tank lid and fill with hydraulic oil and replace the tank lid. Connect the hydraulic hose to the power pack.



22. There are 4 top post covers included (one for each post).

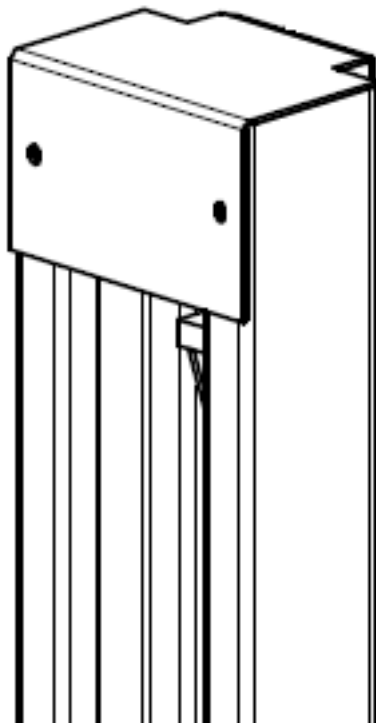

All Electrical Work to be Performed by a Licensed Electrician

23. Connect the main plate conduit tube and the control panel cable with the connection cable (purple) and assemble the power pack tank cover. (Connection line, tank cover – power pack front vinyl cover)

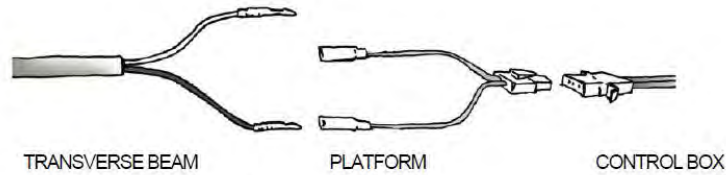

24. Connect the power pack main supply.

NOTE! Requires 3 active and earth.

- Input voltage tolerance should be $\pm 10\%$
- Frequency tolerance should be $\pm 1\%$
- There must be a 10A over current protector installed in the input power line.
- The diameter of power supply cable should be 2.5 mm^2
- Bind the hydraulic hose and wiring with cable ties.

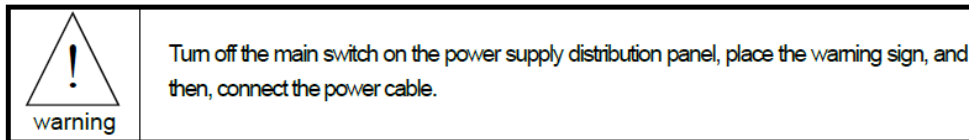

By this stage of the installation, please ensure that grease has been applied to all pulleys on the hoist. This includes the four transverse beam pulleys as well as the front and rear pairs of pulleys under the platform. (Pulley pins are supplied with grease nipples for easy greasing) This should be performed ONCE A WEEK.

Levelling the Cables

25. Turn on the hoist and raise up the hoist and press the locking switch to tighten the cable. (Raise the hoist to the position comfortable to work under the platform)
26. Fasten the cable clamp on the cylinder fixing cable and the drive plate.
- NOTE!** Clamps must be tight, retighten again at the end of the installation.
- NOTE!** To avoid the cable clamps rubbing the cables, adjust and angle the cable clamps as shown below and keep separated by approx. 10cm

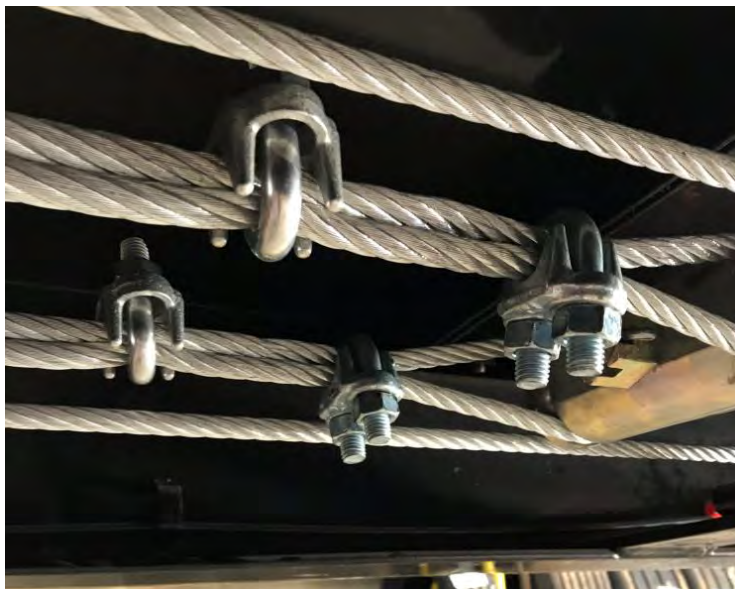

27. For the final levelling of the platforms, raise the platforms to the 4th from bottom lock position and then press the lock button. Pull the cables in each of the 4 posts evenly and tighten the cable end bolts with a spanner.

NOTE! It is very important to recheck the levels with the heaviest vehicle available (under the hoist capacity of 4000, 5000, or 6000kg depending on model)



28. Install the other top post covers and the transvers beam pulley covers.

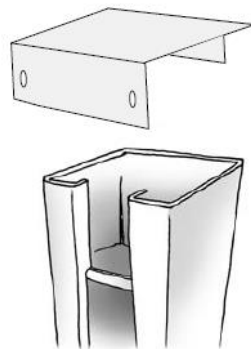

29. Assemble the run-up ramps and lift into position on the platforms and slide the pins through and fit circlips.

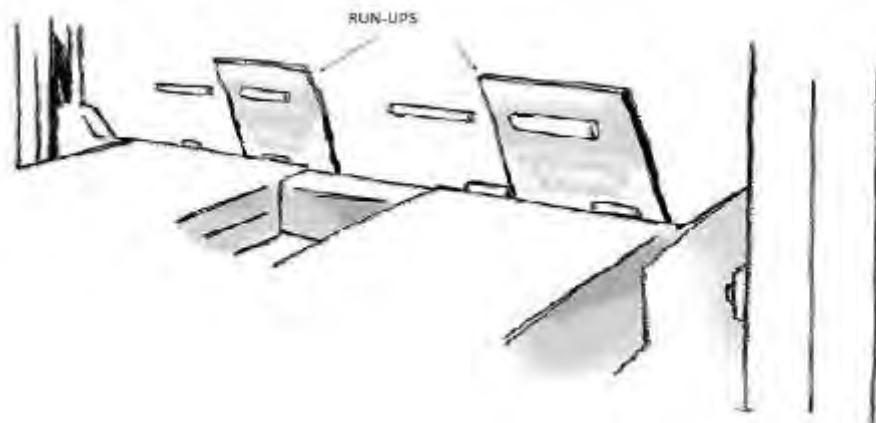

Installer Checklist

Installer must complete (tick) the following list after installing the hoist:

- Legal clearances around hoist
- Floor is suitable and within manufactures specifications
- Cables, pulleys and/or hoses are free of any damage
- All pulleys/pins have been greased. (Transverse beam and platform pulleys)
- Safety devices, limit switches and controls have been checked for correct operation
- Hydraulic system checked and leak free at time of installation
- Hoist tested without and with load as per manufactures specifications
- Hoist has been lubricated and adjusted as per manufactures specifications
- The client representative has been shown and instructed in the correct operation and maintenance of the hoist

Distributor (vendor)

Company _____

Branch _____

Hoist

Installation Date _____

Model Number _____

Serial Number _____

Hoist Owner

Business _____

Name _____

Position _____

Signature _____

Installer Details

Name _____

Company _____

Signature _____

These records should be retained for administrative and warranty assistance.

Cable Arrangement Diagram For 4 Ton and 5 Ton 4 Post Hoists

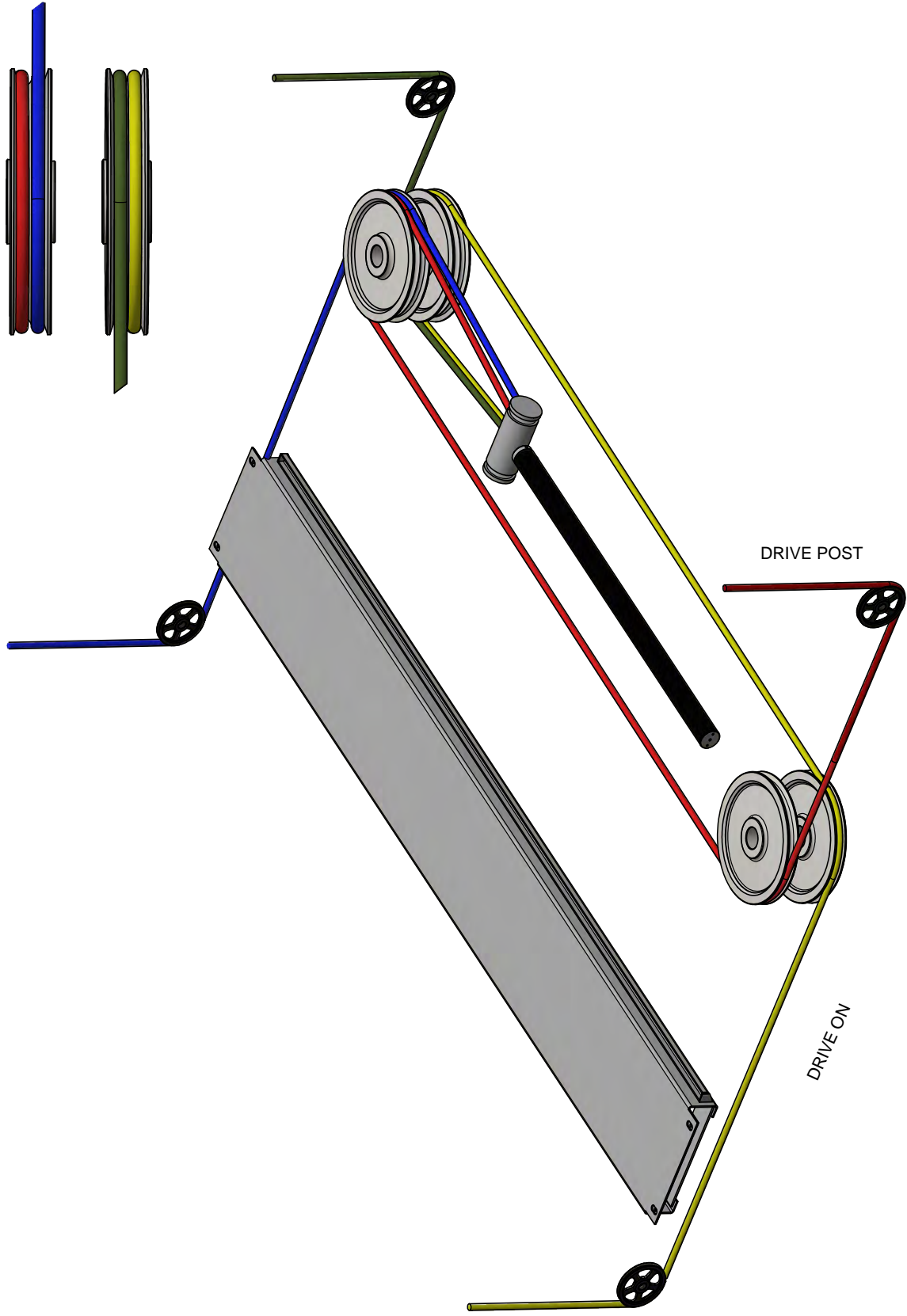

Cable Arrangement Diagram For 6 Ton 4 Post Hoists

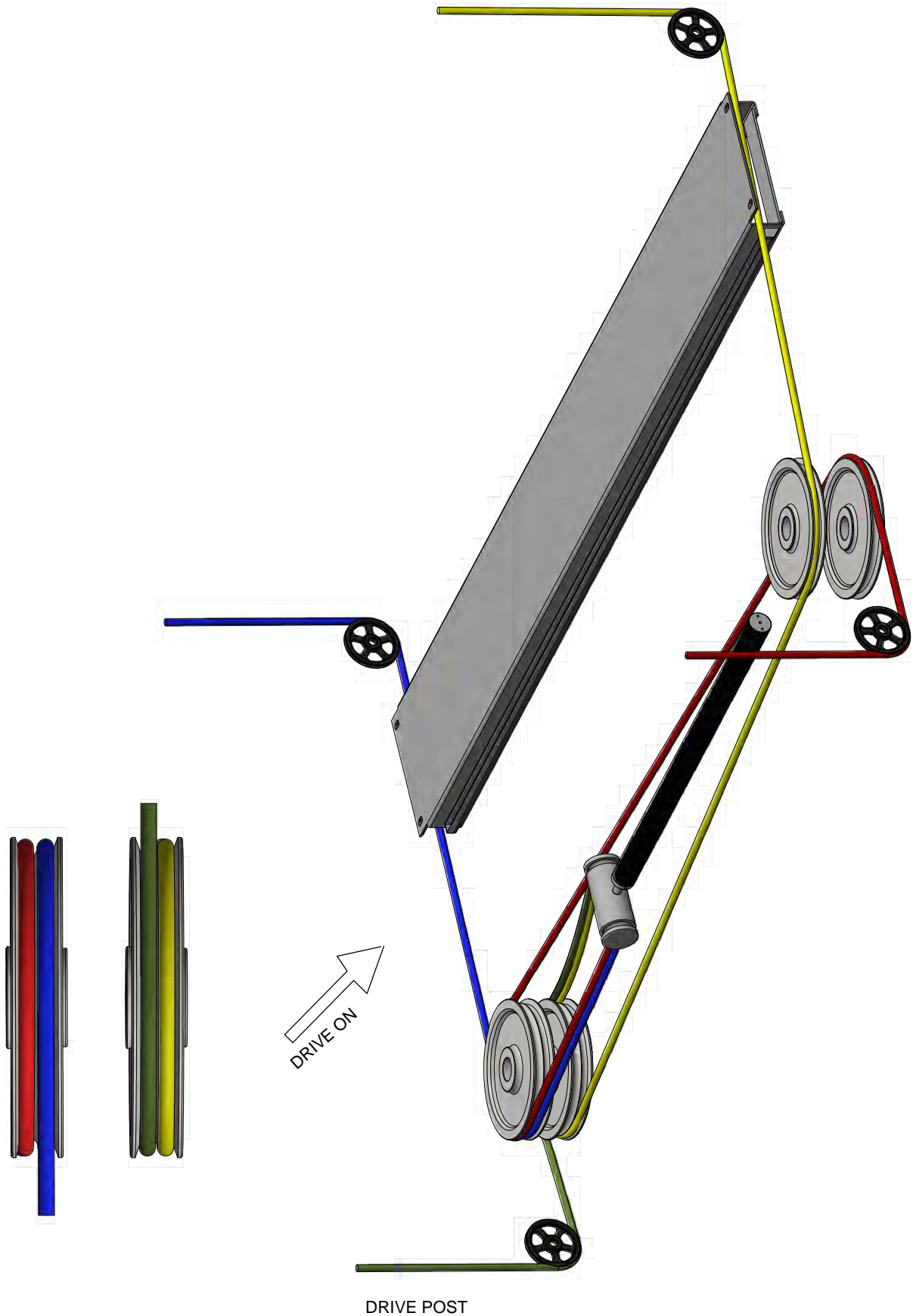

RH-4PKS-4000 / RH-4PKA-4000 / RH-4PKS-5000 Layout Drawing

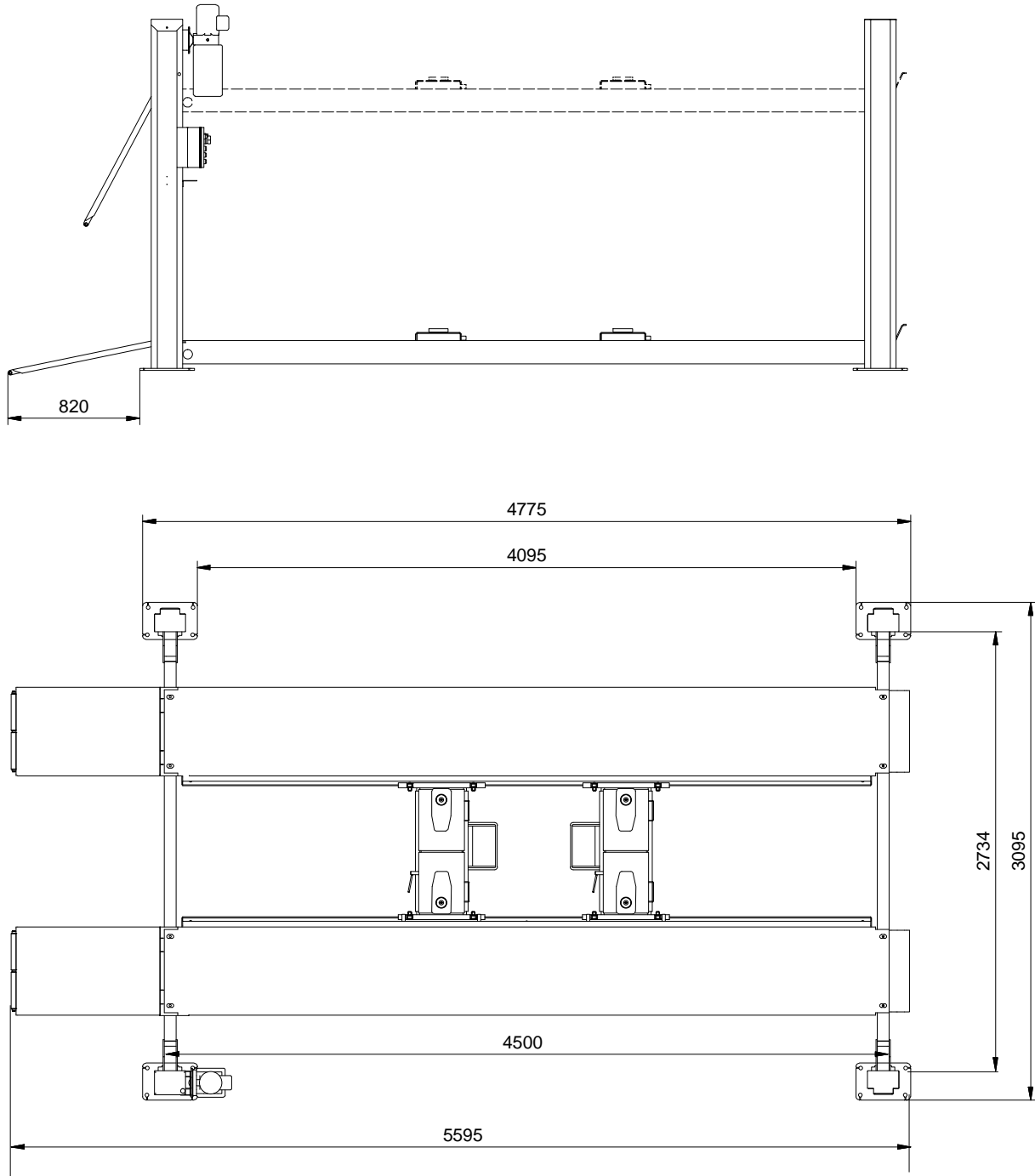

RH-4PKA-5000 Layout Drawing

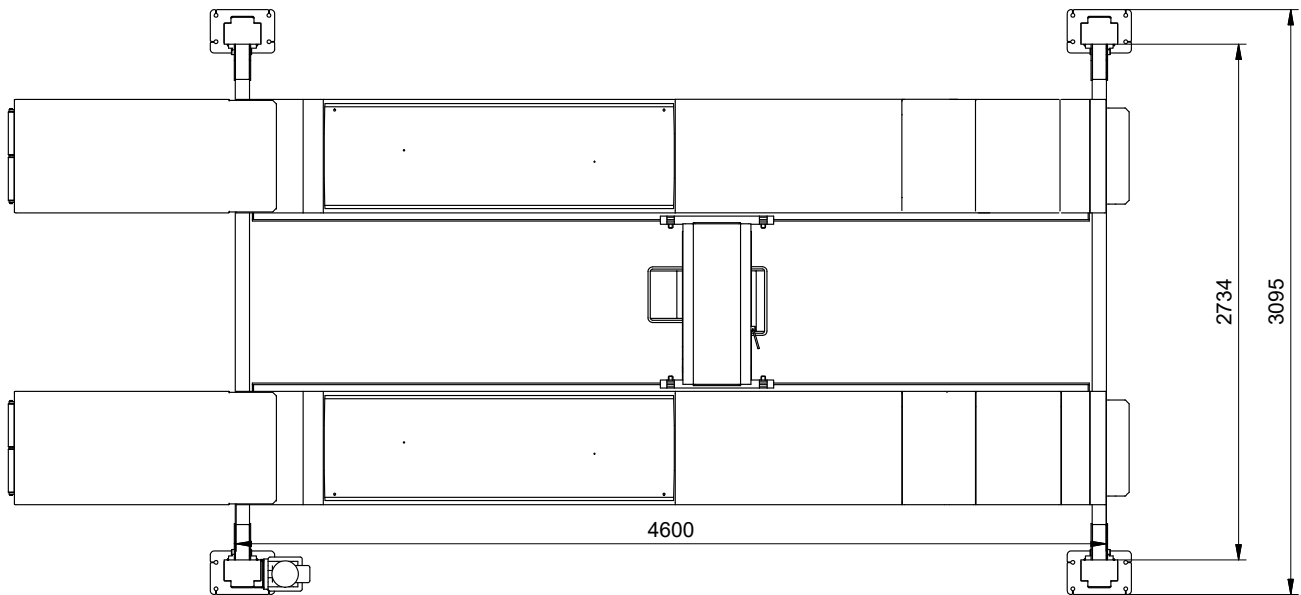
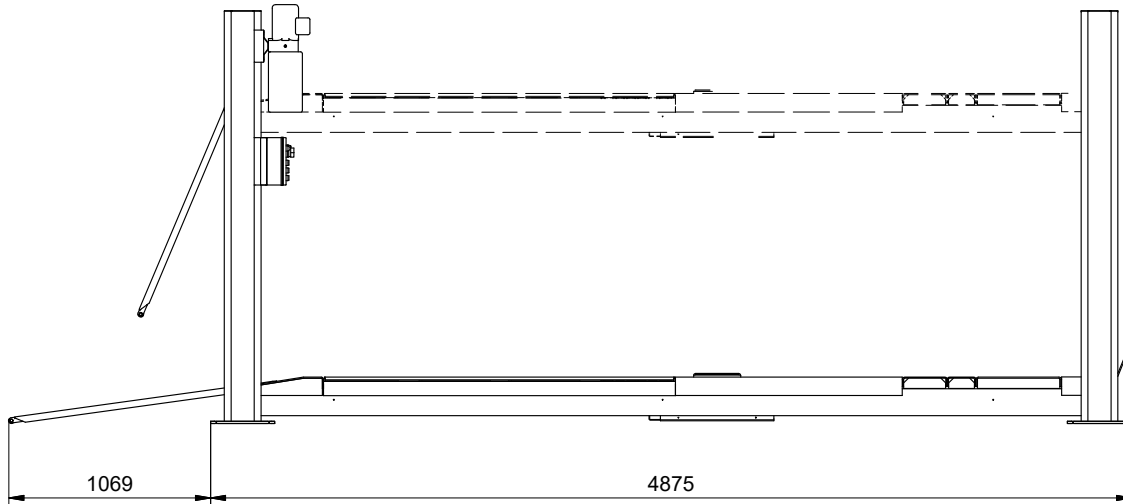

RH-4PKA-5000L Layout Drawing

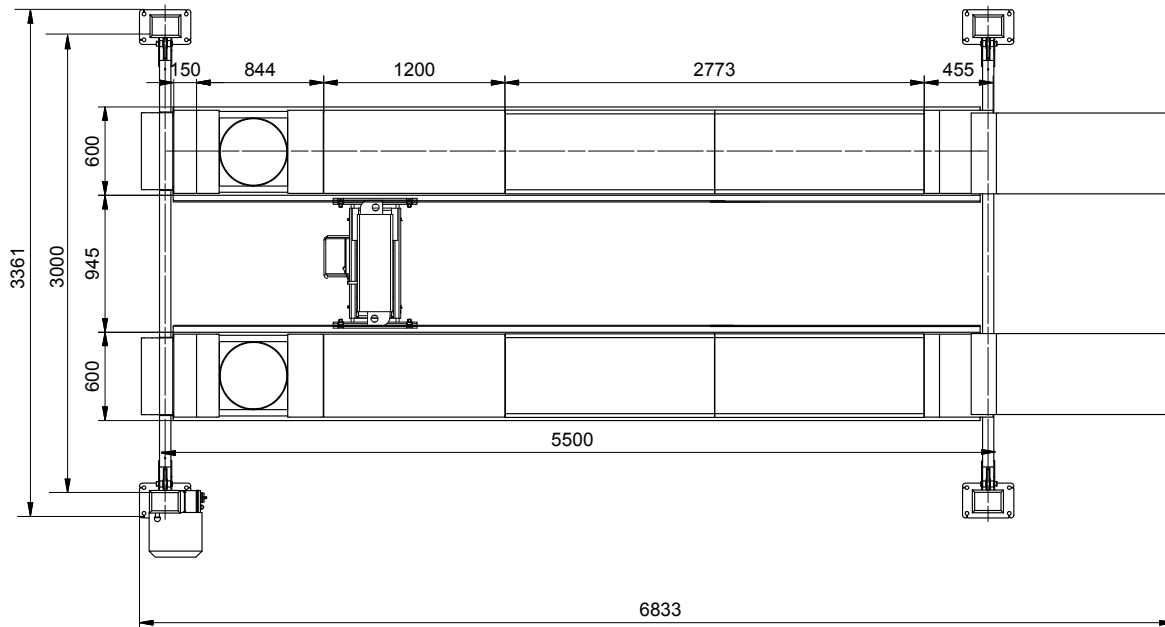
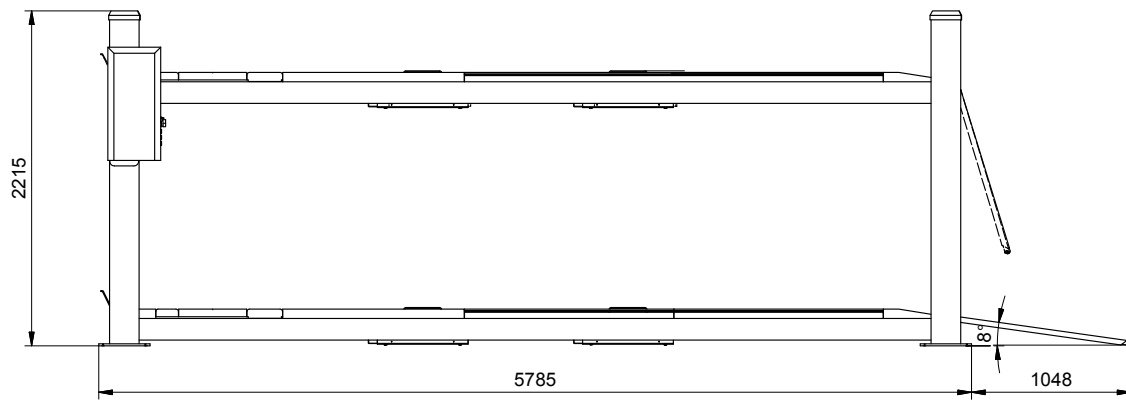

RH-4PKS-6000 / RH-4PKA-6000 Layout Drawing

