

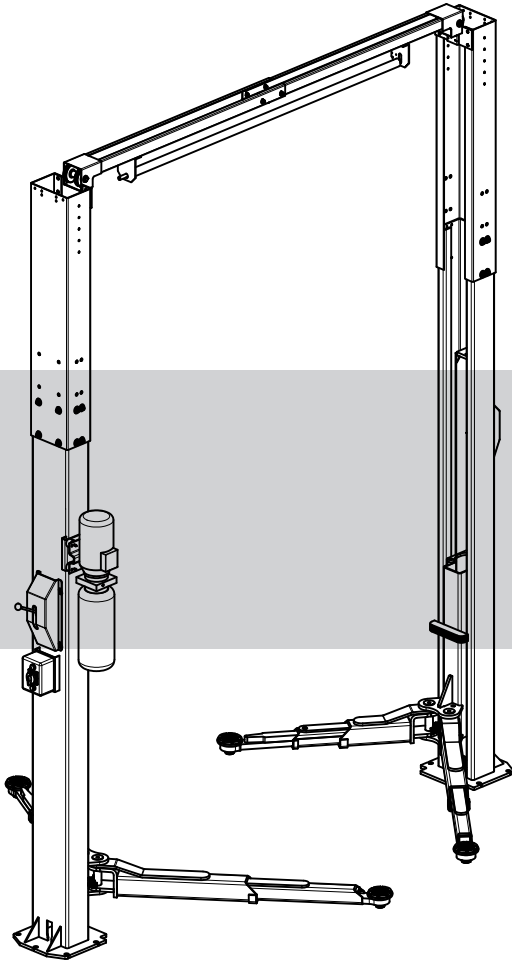

CENTURY 2 POST LIFT

Installation/Operation & Maintenance Manual



CEN-4000B

Please read this manual before you get started.

You must read and understand the precautions for safety purposes and any damages that may occur to your property.

NOTE TO THE USER

Thank you for purchasing CENTURY CAR LIFT
Please read this instruction carefully for safety and proper use of the car lift,
and retain it for future reference.

- This Manual is for model : CEN-4000B
- As for the assurance of safety in design and construction of car lift, read this Manual first.
- Please make sure that this Manual is delivered to end users for their implementation of safety.
- Don't use the car lift in a potentially explosive atmosphere.

ANY PART OF THIS PRINT MUST NOT BE REPRODUCED IN ANY FORM
WITHOUT PERMISSION.
THIS PRINT IS SUBJECT TO CHANGE WITHOUT NOTICE.

TABLE OF CONTENTS

| | |
|---|----|
| Introduction | 4 |
| Features and Characteristics | 4 |
| Part Descriptions | 6 |
| Description | 7 |
| Specification | 7 |
| Safety | 8 |
| Danger/Warning/Caution | 8 |
| Installation Procedures | 10 |
| Checklist Before Installing | 10 |
| Place of Installation–Layout | 11 |
| Operation | 16 |
| Check Points Before Operation | 16 |
| Operation | 17 |
| Operation Procedures of Each Part | 28 |
| Maintenance | 20 |
| Maintenance | 20 |
| Troubleshooting | 23 |
| Check List and Periodic Maintenance | 24 |
| Part List | 25 |

Introduction

Safety

Installation

Operation

Maintenance

Part List

This manual was prepared in January of 2015, the product specification contained in this manual are subject to change without notice.

Features and Characteristics

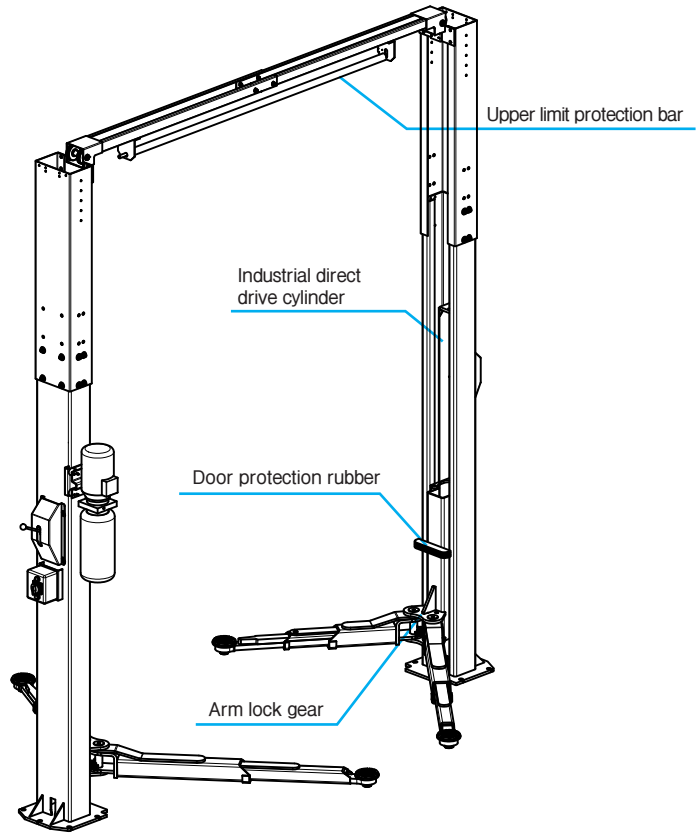

■ Upper limit protection bar

► A limit bar prevents the vehicle from being lifted too high. This feature effectively protects taller vehicles from being damaged.

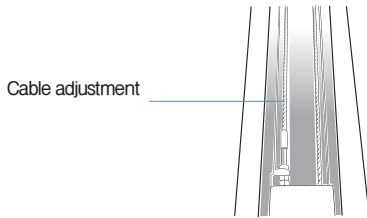

■ Cable adjustment

- ▶ Correct adjustment ensures synchronization of both carriages.

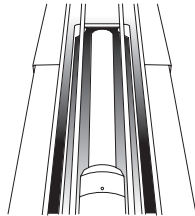

■ Operation of ram type cylinder

- ▶ Two individual cylinders ensure reliability and longevity.

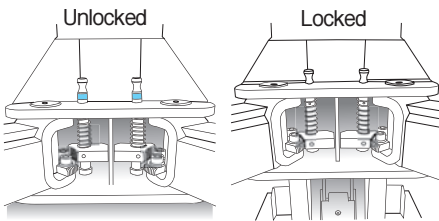

■ Powerful arm lock gear

- ▶ At the bottom position the gears are unlocked to allow arm adjustment. When the lift is raised the gears are automatically locked ensuring complete safety.



■ Door protection rubber

- ▶ Vehicle door protect during working.



■ Safety locker

- ▶ Safety locker system.

Part Descriptions

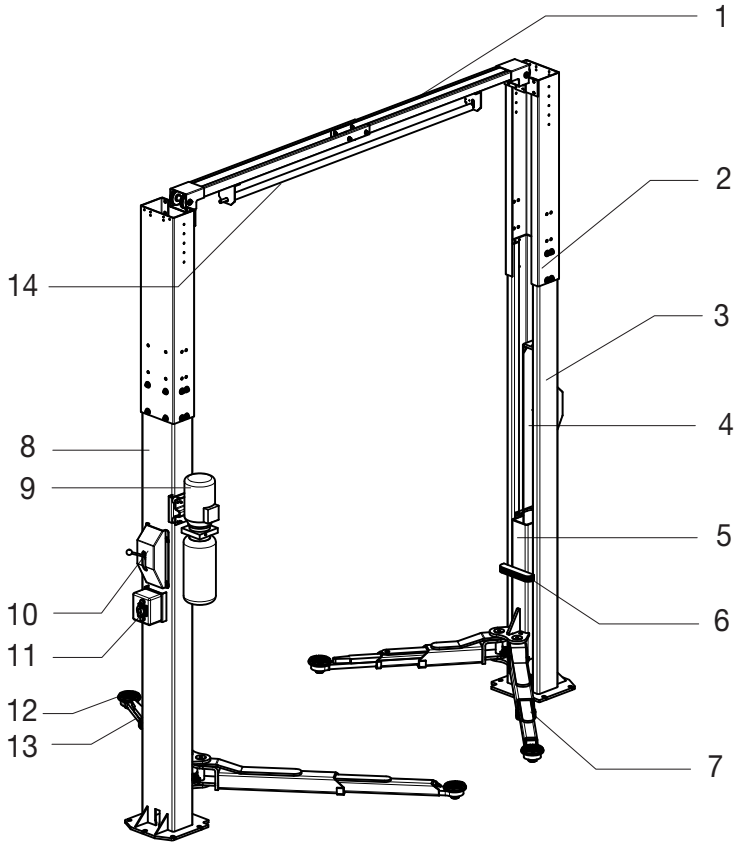

| | | | |
|---|----------------------------|----|-------------------------------|
| 1 | Cross beam | 9 | Power Pack |
| 2 | Post extension | 10 | Locker cover & Locker(inside) |
| 3 | Slave post | 11 | Control box |
| 4 | Cylinder | 12 | Pick-up pad |
| 5 | Carriage | 13 | Short arm |
| 6 | Door protection rubber pad | 14 | Top limit touch bar |
| 7 | Long arm | | |
| 8 | Drive post | | |

Description

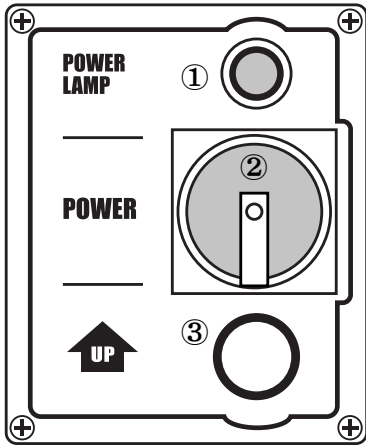

■ Functions (Control panel)

- 1. Main power lamp**
- 2. Main switch**
 - To connect or disconnect power to the lift.
- 3. Ascend button**
 - To raise the lift.

Introduction

Specification

| | |
|---------------|----------------------------|
| MODEL | CEN-4000B |
| CAPACITY | 4,000 Kg |
| MAX. PRESSURE | 14 Mpa |
| MAX.HEIGHT | 1,895~1,940 mm |
| MIN. HEIGHT | 95~140 mm |
| STROKE | 1,800 mm |
| LIFTING TIME | Approx. 45 ~ 60 sec |
| LOWERING TIME | Approx . 35 ~ 50 sec. |
| POWER&MOTOR | 3Ph 2.2Kw 2Poles 415V 50Hz |
| NET WEIGHT | About 700 kg |

Danger/Warning/Caution

Rules for illustrations in the manual

These are the rules for the illustrations in the manual. Make sure that you read and understand them.



| | |
|--|---|
| | Make sure you follow the instructions, otherwise critical injuries can occur. |
| | Make sure you follow the instructions, otherwise critical injury or damage can occur. |
| | Make sure you follow the instructions, otherwise injury or damage can occur. |
| | The terms are described to enhance the understanding of the equipment. |
| | Information to use the equipment efficiently. |
| | Precautions or check points for the use of the equipment. |
| | Please refer to the page |



Do not come under the vehicle during operation.

► It may cause severe injuries.



Evacuate to a safe place instantly in the event that the vehicle tips.

► It may cause severe injuries.



Do not overload the rated capacity.

► It may cause severe injuries.

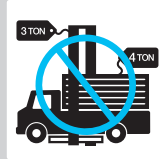

※ Not following the instructions can lead to a critical accident involving your life. Make sure you follow the instructions.



Warning before using the equipment

Only trained personnel may operate the equipment. Inexperience can cause accidents.



Position the vehicle to make sure that it is balanced front and rear, right and left (otherwise the vehicle may fall off).

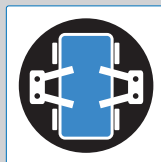

Do not operate damaged equipment (a critical accident could occur – contact your supplier)



After that a vehicle is placed on the lift make sure that the hand brake is applied. Passenger transport is forbidden.





Warning when operating

Allow no unauthorized persons in the work area.



Before lowering the lift, check that there are no obstructions under the vehicle or the lift arms.



When the vehicle is lifted, do not rock it as this may dislodge it.



Do not lift a vehicle using one pair of arms only.

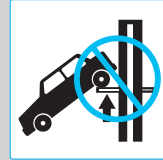

Warning when operating

To avoid injury, keep your feet clear of the arms and carriages.



Before going under the lift, make sure that the safety pawls are engaged.



To avoid being electrocuted, disconnect the main power before opening the control panel.



Do not modify the control panel or the safety functions as this may impair their function.

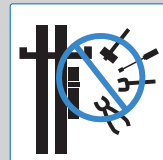

Warning when operating

Do not rock the vehicle when lifted. Do not use a high pressure cleaner as the vehicle lower part.



Read and fully understand the manual before using the lift.



Warning before using the equipment

Check the safety devices to see that they are clean and operable.

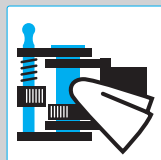

If the lift is idle for a long time, disconnect the main power supply. In the event of thunder storm, disconnect the main power supply.

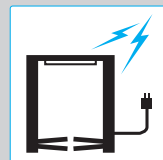

Check List Before Installing

Installation site

The site must be flat and horizontal. The floor must have minimum 160mm depth of reinforced concrete.

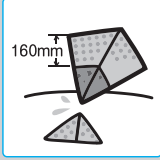

Surface load under the posts must be minimum 25N/mm²



Ambient temperature 10°C to 50°C. Do not operate under freezing conditions.

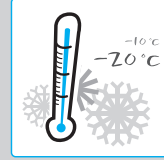

Installation

Installation site

Vehicle access to the lift must be safe and easy.

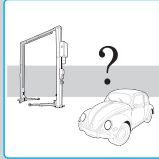

There must be a safe working distance of minimum 1m between the lift and the wall or any fixed object.

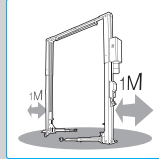

To ensure that the anchor is secure, the hole for an anchor bolt must be more than 2/3 of the bolt length.

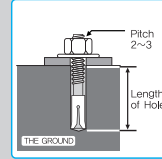

Installation site

To maintain the warranty, the lift is intended for indoor installation only. In the event that it is installed outside it should be protected from snow and rain. Outdoor installation makes the warranty invalid.



Skilled engineers of CENTURY or its sales representative agency shall install the lift, otherwise a failure may occur.

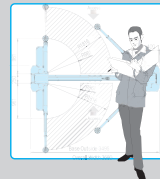

The lift should be installed by skilled engineers either from CENTURY or from the appointed representatives. Failure to observe this makes the lift warranty invalid. If the lift is to be moved to another site at a later date, it must be reinstalled by skilled engineers either from CENTURY or the appointed representatives.

Place of Installation–Layout

Check points before selecting the place of installation.

- ① Distance from wall or any fixed object
- ② Drive-on direction
- ③ Positions of power post and slave post
- ④ Ceiling height and height of cross member

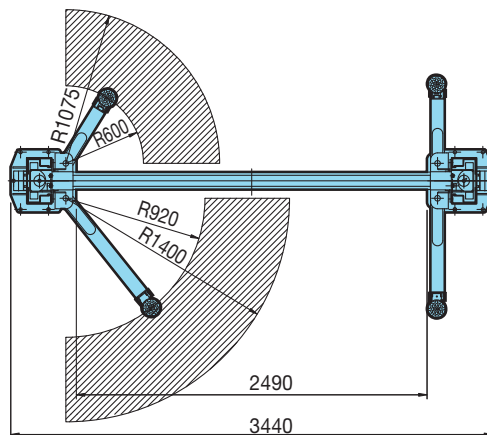
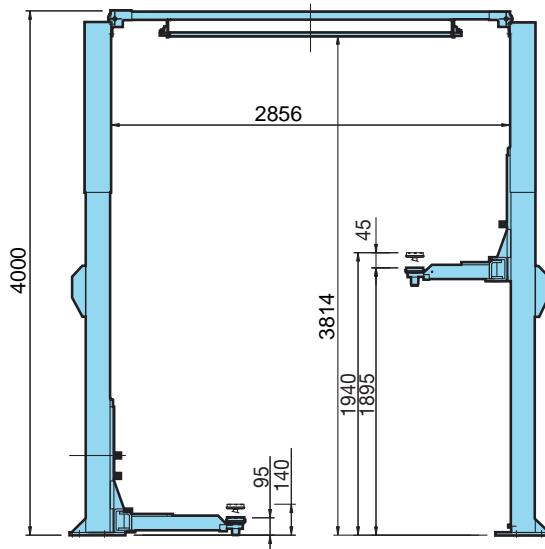

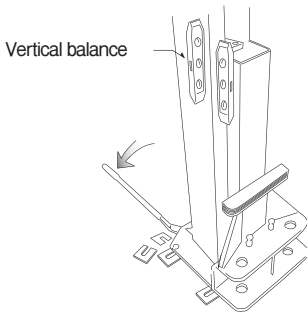

■ Setting up a post

► Before securing with anchor bolts, ensure that the post is vertical in both directions.

1 Adjusting verticality

Check that the post is vertical in both directions and adjust by means of the shim plates provided.

2 Fixing the post

Fix by anchor bolts.

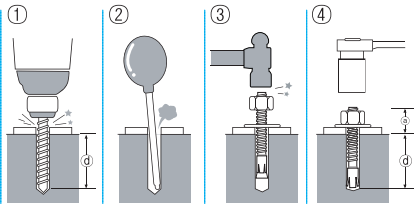

Anchor bolt installation

- ① Drill a hole
- ② Clean the inside of the hole
- ③ Put an anchor bolt into the hole and hammer it until it reaches the bottom of the hole
- ④ Tighten the bolt with a spanner (Ⓐ:35~45mm)
(Tighten more 80N.m~100N.m)

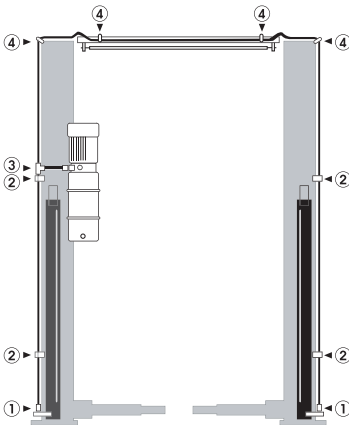

■ Connection of the hydraulic hose

► Before setting up the post, connect the hydraulic hose and tighten it with a spanner. Check for oil leakage.

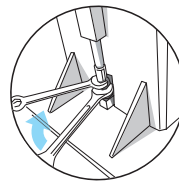

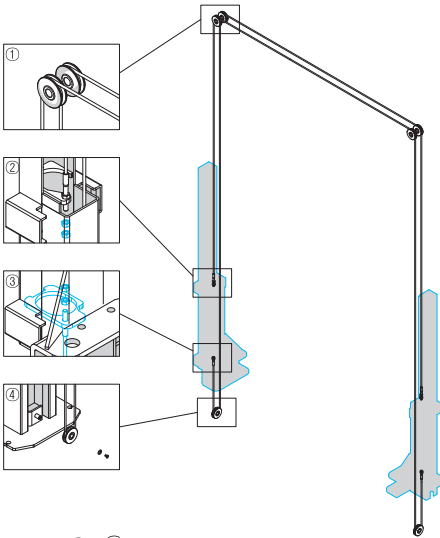

■ Cable synchronization

► The cables ensure synchronization between the carriage on the power post and the carriage on the slave post.

- ① Top roller for cable.
- ② Synchronization cable from the opposite carriage.
- ③ Synchronization cable mounting bracket.
- ④ Bottom roller for cable.

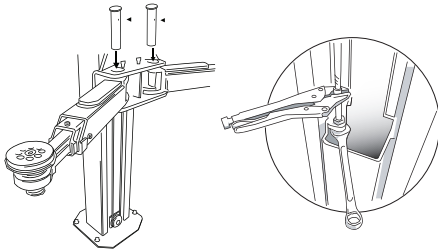

Adjusting the cables

Check which carriage touches the base plate of the post firstly when the lift descends, and then tighten it's cable until both carriages rest on the base plates simultaneously.

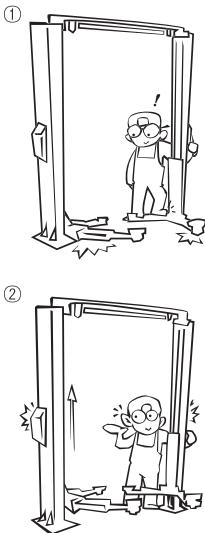

How to check the tuning adjustment.

- ① Check with "naked eyes" that the bottom post reached simultaneously see above.
- ② Check with ears
Check the sound of the parking pawls engaging in each slat during ascend. The "clicks" should be simultaneously if not tighten the cable on the later pawl. (The wire of the locker that sounds later shall be tightened more tensely.)

Hydraulic Diagram

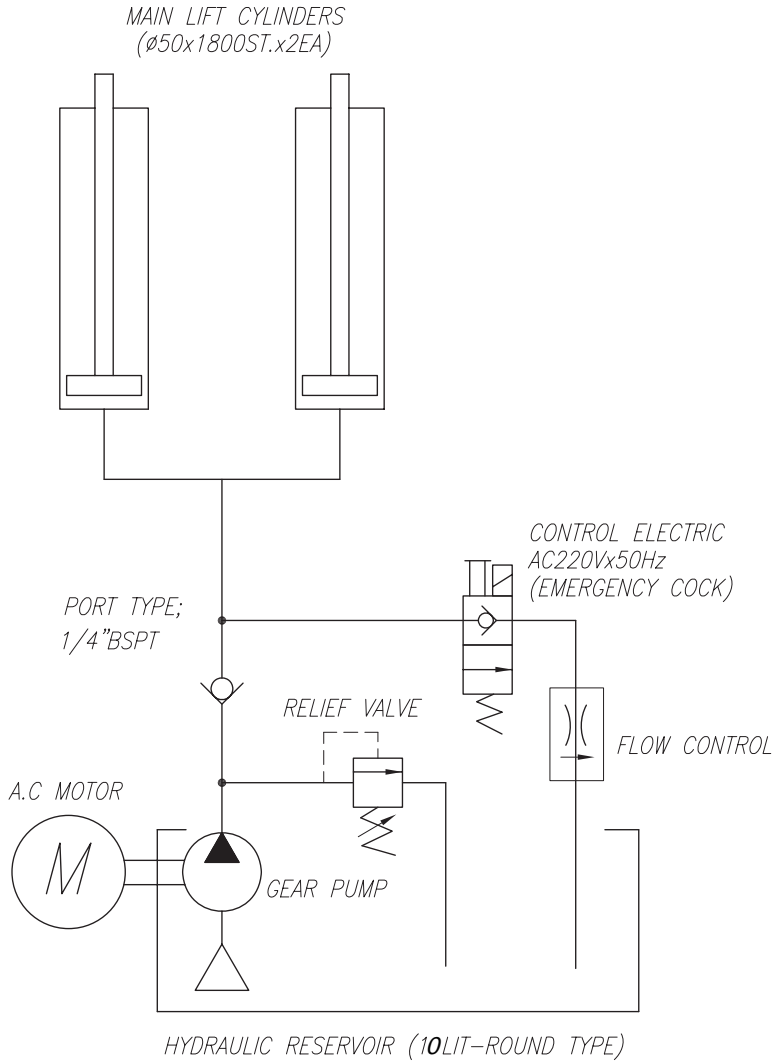

Electrical Diagram

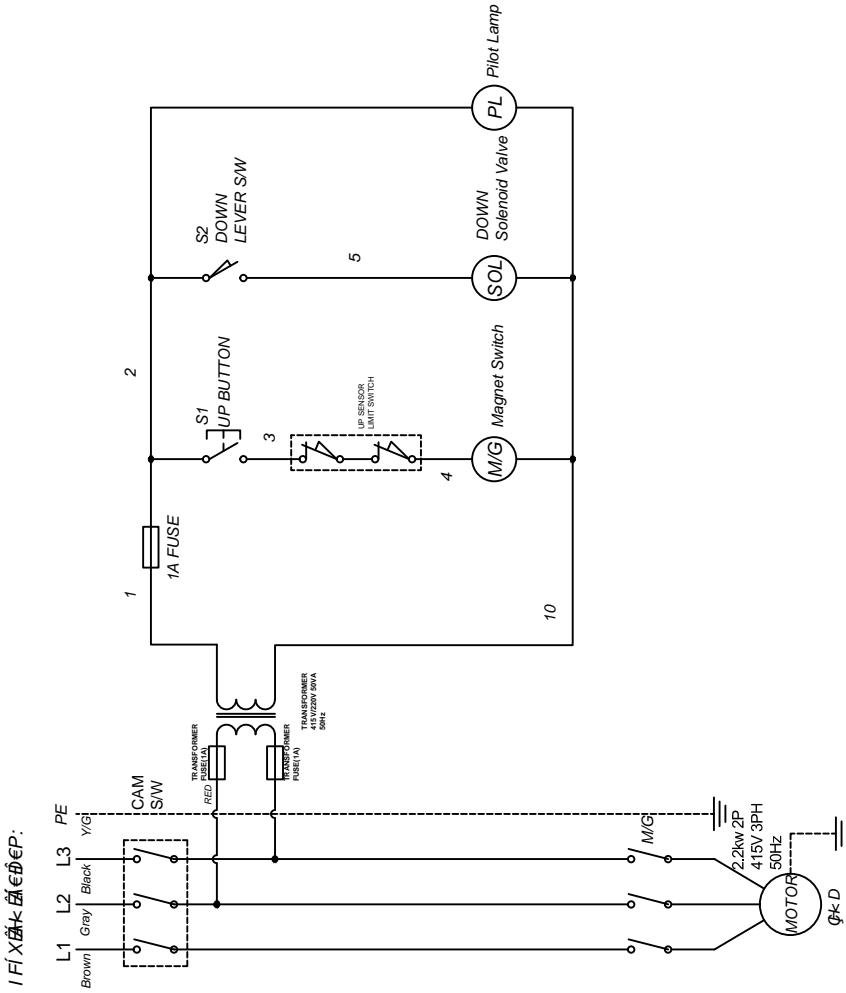

Installation

Check Points Before Operation

Before loading the lift check the following points.

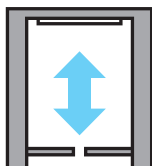

■ Test Operation

▶ Operate the lift up and down 2–3 times to check the full travel of the carriages.



■ Switch Operation

▶ Check that the ascent and descend lever operate correctly.

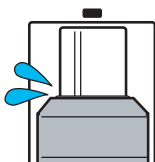

■ Hydraulic Check

▶ Check that there are no hydraulic leaks from either cylinders, pipes, or hose joints.



■ Mechanical Check

▶ Check the tightness of all nuts, bolts, etc.

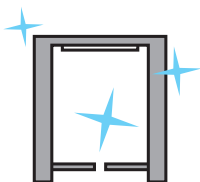

■ Exterior Check

▶ Check the exterior of the lift to ensure that there is no obvious damage.

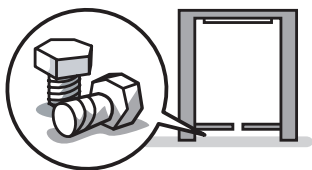

■ Cleanliness

▶ Check every day that the lift and the work area are clean and free from debris or obstructions.

Operation

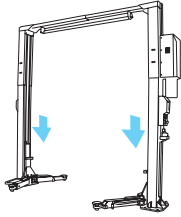

1 Prior to use

Check that the carriages and arms are at lowest position by operating the descend push button.

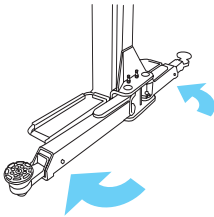

2 Prior to vehicle entry

At the bottom position the arm locks are released. Swing the arms to the straightahead position as shown.

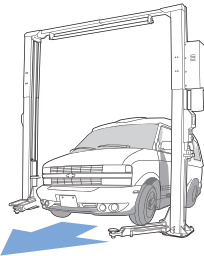

3 Vehicle entry

Position the vehicle centrally between posts with the vehicle's center of gravity in line with the 2 posts.

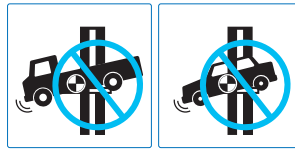

4 Arm and pad adjustment

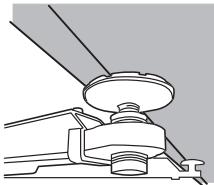

Swing in the 4 arms under the vehicle and adjust the length of each arm so that the pick-up pad is directly underneath the pick-point recommended by the vehicle manufacturer. Each pad is fitted with telescopic thread allowing a 2-stage adjustment. Adjust the height of each pad to engage the pick-up point.

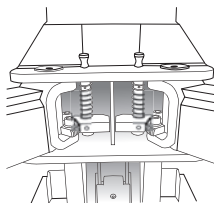

5 Check the arm locks

Raise the lift approx. 50mm and check visually and mechanically to ensure that each arm lock is firmly engaged.

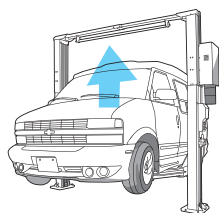

6 Ascend

After checking that the 4 pads are correctly adjusted under the pick-up points recommended by the vehicle manufacturer and that the arm locks are engaged as previously described, press the ascent push button and raise the lift to the required working height.



7 Vehicle repairs

Before going under the lift, check again visually the pick-up pads and arm locks. After repair of the vehicle, check the floor and work area to ensure that there are no obstructions. Press the descent push button to lower the lift. When the lift is at the bottom position, the arm locks are released automatically. Release the pick-up pads from the pick-up points by screwing down the telescopic threads. Swing the arms from under the vehicle to the straight-ahead position and remove the vehicle.

Operation Procedures of Each Part

Operation

■ Arm Lock Operation

1 Ascend

When the carriages go up the arm locks are engaged automatically. Ensure that the gears controlling the locks are in mesh, i.e. fully engaged. If not, the arm must be marginally adjusted until the spring loading operates and locks successfully.

2 Descent

At the bottom position the locks are automatically disengaged.

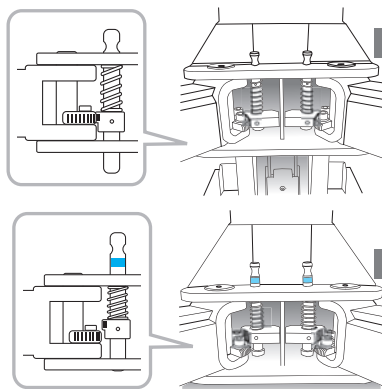

■ Arm Operation

1 Adjustment of arm length

the arms are telescopic with either 2 sections or 3 sections as shown to allow the required adjustment.

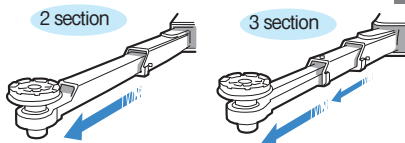

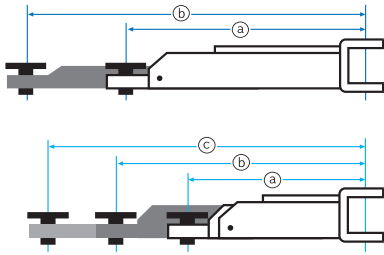

Lifting Arm

2-section telescopic arm

- (a) 920 mm
- (b) 1400 mm

3-section telescopic arm

- (a) 600 mm
- (b) 850 mm
- (c) 1075 mm

2 3-stage telescopic pad adjustment

The height of the pad can be adjusted 3 stages as shown below.

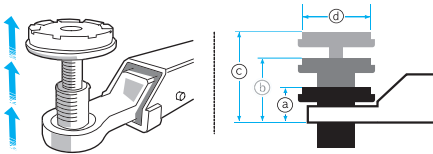

- (a) 55 mm
- (b) 75 mm
- (c) 100 mm
- (d) Dia.120mm

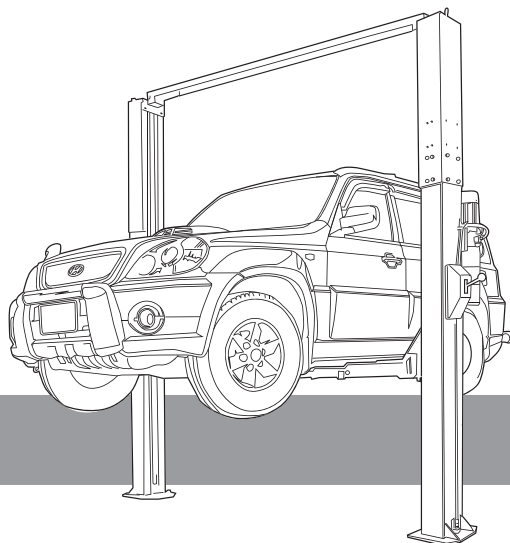

Maintenance

■ Lubrication

► At 2 or 3 month intervals, depending on service usage.

1 Molybdenum disulphide grease

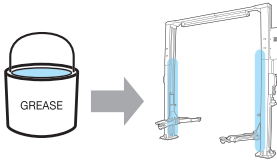

► Apply molybdenum disulphide grease liberally to the carriage guides and the guide runners inside the posts.

2 Lubricating oil

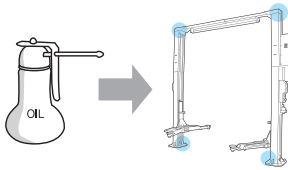

► Lubricate with oil the upper and lower cable rollers and axles.

■ Cleanliness

► Check every day that the lift is clean and that the work area is clean and free from debris or obstructions.

► Clean safety devices at 2 or 3 month intervals, depending on service usage.
– Clean the arm lock gears and surroundings, lubricate the gear teeth and the release mechanisms. Clean the safety lock pawls, and lubricate the axles.

■ Synchronization Cable Adjustment

► Check that both carriages are fully parked on the base of the lift at the bottom position. Raise the lift without load and listen to the audible clicks of the 2 lock pawls. The synchronization of the 2 carriages is correct when both lock pawls click simultaneously. Adjust the length of the 2 cables as shown to fulfill this.

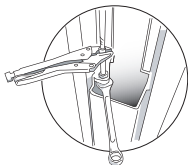
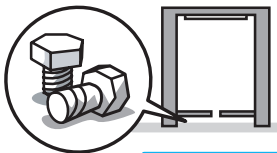

■ Arms

► Once a year check the condition of each arm by sliding each section to its fully extended position and ensure that the arm stop is working correctly.

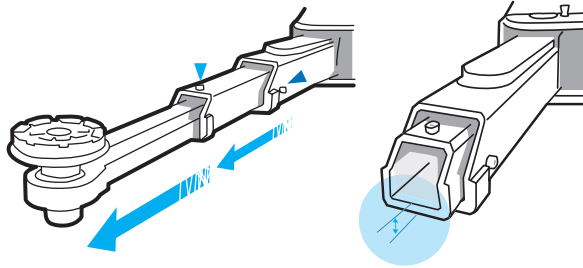

■ Emergency lowering in the event of power failure

In the event of a power failure the lift must be lowered manually. Lift each carriage by approx. 30mm using a trolley jack and a suitable extension to this and manually release the lock pawls. Fix the lock pawls mechanically so that spring pressure does not re-engage them. Remove the trolley jack and extension. Repeat this operation on the opposite carriage. Remove the trolley jack and extension. As a safety precaution before opening the power pack, switch off the mains and switch off the lockable main switch on the control panel.

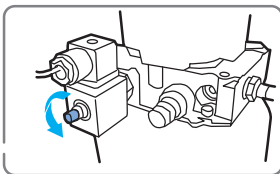

Turn the emergency cock lever slowly and carefully anti-clockwise to ensure that the lift lowers slowly and safely.

Steps after completing the operation

Turn the lever clockwise and lock it securely.

2 Power pack pressure



The power pack pressure is set by the factory in accordance with the lift's maximum rated capacity. The pressure regulator is sealed by the factory and should not be tampered with. Excessive adjustment can result in serious damage. If the lift fails to raise the maximum rated load, contact your Heshbon approved maintenance engineer.

Standard pressure settings model

CEN-4000B

14 Mpa

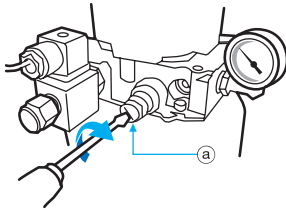

Do this action

If machine can't lift 4,000kg,

- ① Put the pressure gauge.
- ② Open the cap of relief valve and adjust put up button.

3 Oil change

Oil should be changed 2 months after installation and thereafter annually.

Oil change procedure

- ① Remove the cover of the hydraulic unit.
- ② Remove the oil filter cap and dipstick.
Carefully remove the oil drain plug and allow the oil to discharge into a suitable container.
- ③ Refit the drain plug and tighten
- ④ Refill the oil tank with new oil
- ⑤ Check with the dipstick that the level is correct : raise and lower the lift and recheck that the level is still correct. If not, top up with oil.
- ⑥ Refit the cover

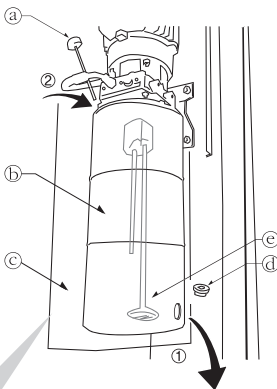

- a) Filter cap and dipstick
- b) Oil tank
- c) Drain plug
- d) Pump filter

- ① Oil filter
- ② Oil discharge



At the annual oil change, after having drained the oil tank, remove the oil tank from the pump and check the condition of the pump filter. Clean or replace as necessary. Replace tank and follow the above procedure.

Troubleshooting

| | Symptoms | Check point | Corrective Action to be taken |
|-------------------------------------|---|---|---|
| Wire cable and Locking device | Carriages and arms do not synchronize during lifting. | <ol style="list-style-type: none"> 1. Check if wire rope is partially loosened. 2. Check if clip of wire rope is loosened. | <ol style="list-style-type: none"> 1. Readjust the fixing bolts of the wire rope to ensure that the carriages are leveled. 2. Tighten clips after adjustment. |
| | Lift does not lower when down lever is operated or if down button is operated independently | <ol style="list-style-type: none"> 1. Check if the safety lock is engaged in the carriage and under load. 2. Check the electrical power is available at the down button and solenoid valve. | <ol style="list-style-type: none"> 1. Raise the lift, disengage the safety lock with the down lever, and lower the lift. 2. Repair the electrical connections if possible, alternatively lower the lift in accordance with the manual descend procedure. |
| | Carriages and arms do not synchronize during lowering. | <ol style="list-style-type: none"> 1. Check if the oil at top lifting position is sufficient. 2. Check if the air is mixed in the hydraulic oil. | <ol style="list-style-type: none"> 1. Top up the oil tank to the correct level. 2. Bleed the air from the hydraulic unit |
| | Safety lock does not operate during lifting or lowering. | <ol style="list-style-type: none"> 1. Check the connection of wire and connector. 2. Check the operation of manual lever. | <ol style="list-style-type: none"> 1. Reconnect if necessary. 2. Release manual lever. |
| Hydraulic system and its components | Abnormal noise from the motor. | <ol style="list-style-type: none"> 1. Rated capacity is exceeded. 2. Relief pressure is low. 3. Shortage of hydraulic oil. | <ol style="list-style-type: none"> 1. Operate within rated capacity. 2. Adjust to 4.5 ton. 3. Bleed the hydraulic unit after topping up the oil level. |
| | Hydraulic oil leakage | <ol style="list-style-type: none"> 1. Defective hydraulic hoses 2. Leakage from hydraulic unions 3. Lead age from cylinder high pressure seal | <ol style="list-style-type: none"> 1. Replace the hydraulic hose. 2. Tighten the union connection 3. Request A/S center. |
| | Oil connections | Hydraulic fluid pollution by water or foreign debris. | <ol style="list-style-type: none"> 1. Exchange oil (annually) (Hydraulic oil : 32CST/11liter) First oil change 2 months after installation. Therefore regular oil changes at annual intervals. |
| | The lift does not rise. | <ol style="list-style-type: none"> 1. Check for oil leaks or damage to the hydraulic unit. 2. Check that the correct operating procedure is being used. 3. Check that the load is not above the rated capacity. 4. Check that the pressure valve is correctly adjusted. | <ol style="list-style-type: none"> 1. Request A/S center. 2. Bleed the hydraulic system. 3. Limit the load to the rated capacity or less. 4. Adjust to 4.5 ton. |
| | The lift does not lower. | <ol style="list-style-type: none"> 1. Check if the safety lock is engaged and under load. 2. Check if the electric circuit is damaged. | <ol style="list-style-type: none"> 1. Re-lower after lifting slightly to allow the safety lock to disengage. 2. Refer to electric check points. |
| | | Lower it in accordance with the procedure to lower manually the lift during emergency, and then, request A/S center. | |
| Electric components | Motor does not operate and/or abnormal noise from the motor. | <ol style="list-style-type: none"> 1. Check if the motor is damaged. 2. Check for blown fuses. 3. Check if the push button is damaged. 4. Check if the upper limit is operative. 5. Check that the wire gauge on the electrical supply is correct. | <ol style="list-style-type: none"> 1. Replace the motor (Request A/S center). 2. Replace the fuse after solving trouble. 3. Replace the push button (Request A/S center). 4. Re-operate after lowering the lift. 5. Replace to the cable with over 3,5mm² diameter. |
| | NFB or circuit breaker is operated. | <ol style="list-style-type: none"> 1. Check the Contact of magnetic contactor. 2. Check the capacity of circuit breaker. 3. Check if the wire is damaged. | <ol style="list-style-type: none"> 1. Replacement (Request A/S center). 2. Replacement (Request A/S center). 3. Replacement after checking. |
| | Motor operates but lift does not rise. | <ol style="list-style-type: none"> 1. Check that the phases are correctly connected that the motor rotates anti-clockwise. 2. Check if hydraulic lines is damaged | <ol style="list-style-type: none"> 1. Re-operate after changing the phase connection. 2. Refer to check points for hydraulic cylinder and unit. |

Check list and periodic maintenance

| Inspection period | Points to be checked | Items to be checked | Inspection method | Action to be taken | Replacement period |
|-------------------|-----------------------------------|--|----------------------|--------------------------|---------------------|
| 1 week | Stopper screw for the sliding arm | worn and deformation | Visual | Replacement if necessary | only when necessary |
| | | | | | |
| 3 months | Wire Rope | Abrasion, deformation and Breaking of wire | Visual | Replacement | 2 year |
| | Housing for Arm Lock | Operation of lock | Visual | Replacement | only when necessary |
| | | | | | |
| | | | | | |
| | | | | | |
| | | | | | |
| 6 months | Carriage Guide | Abrasion | Visual / Measurement | Replacement | only when necessary |
| | Hydraulic Oil Level | Shortage of oil | Visual | Replacement | 1 year |
| | | | | | |
| 1 year | Piston Seal | Oil leak or deformation | Visual | Replacement | only when necessary |
| | | | | | |



APPENDIX

PART LIST

MODEL

CEN-4000B

Century Equipment Distributors

This installation manual is prepared on August of 2019. This manual is subject to change without prior notice if the specification is changed.

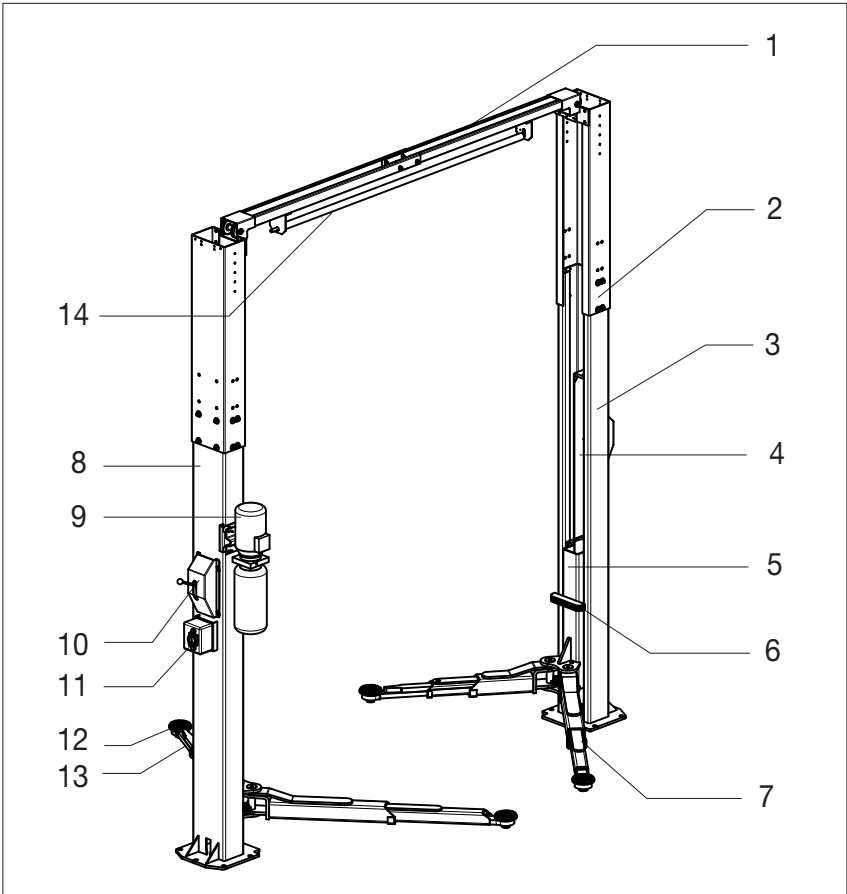

| | | | |
|---|----------------------------|----|-------------------------------|
| 1 | Cross beam | 9 | Power Pack |
| 2 | Post extension | 10 | Locker cover & Locker(inside) |
| 3 | Slave post | 11 | Control box |
| 4 | Cylinder | 12 | Pick-up pad |
| 5 | Carriage | 13 | Short arm |
| 6 | Door protection rubber pad | 14 | Top limit touch bar |
| 7 | Long arm | | |
| 8 | Drive post | | |

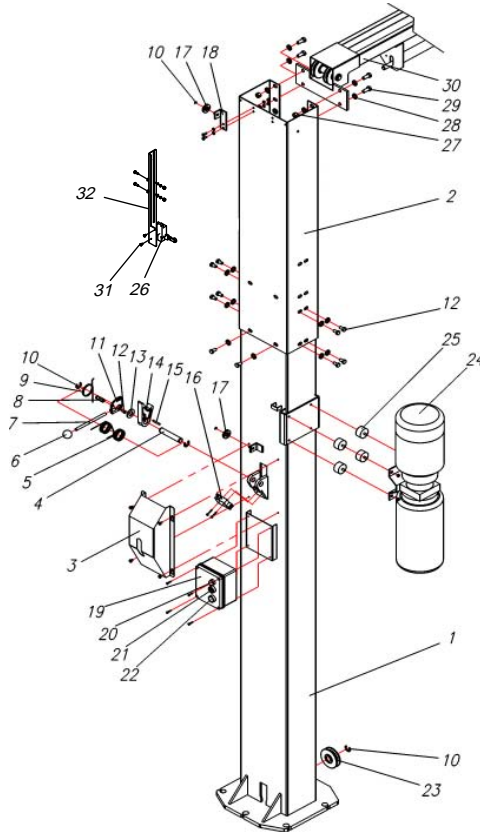

| NO | PARTS NAME | NO | PARTS NAME | NO | PARTS NAME |
|----|-------------------|----|--------------------------|----|----------------------|
| 1 | POST | 12 | WRENCH BOLT | 23 | WIRE ROLLER |
| 2 | EXTENDED POST | 13 | LOCK SPACER | 24 | POWER UNIT |
| 3 | LOCK COVER | 14 | LOCK BLOCK | 25 | ANTI-VIBRATED RUBBER |
| 4 | LOCK SHAFT | 15 | SPRING PIN | 26 | UP LIMIT SWITCH |
| 5 | LOCK SPRING 1 | 16 | DOWN LIMIT SWITCH | 27 | HEXA NUT |
| 6 | LEVER HANDLE | 17 | LOCK WIRE ROLLER | 28 | FLAT WASHER |
| 7 | LEVER SHAFT | 18 | LOCK WIRE ROLLER BRACKET | 29 | HEXA BOLT |
| 8 | LOCK WIRE FIXTURE | 19 | CONTROL PANEL | 30 | UPPER SUPPORT BEAM |
| 9 | LOCK SPRING 2 | 20 | PILOT LAMP | 31 | CROSS HEAD BOLT |
| 10 | E-RING | 21 | CAM SWITCH | 32 | LIMIT SWITCH FIXTURE |
| 11 | LEVER CONNECTOR | 22 | UP BUTTON | | |

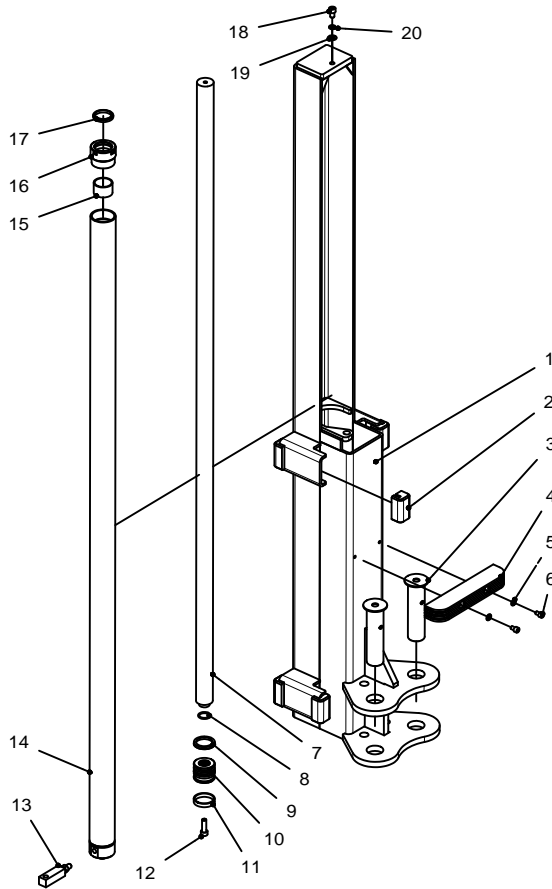

| NO | PARTS NAME | NO | PARTS NAME | NO | PARTS NAME |
|----|---------------------|----|------------------|----|------------------|
| 1 | CARRIAGE | 9 | SEAL RING | 17 | DUST SEAL |
| 2 | CARRY GUIDE | 10 | PISTON | 18 | WRENCH BOLT(M10) |
| 3 | ARM SHAFT | 11 | PISTON RING | 19 | SPRING WASHER |
| 4 | DOOR PROTECT RUBBER | 12 | WRENCH BOLT(M10) | 20 | FLAT WASHER(M10) |
| 5 | FLAT WASHER(M8) | 13 | HOSE ADAPTER | | |
| 6 | WRENCH BOLT(M8) | 14 | CYLINDER TUBE | | |
| 7 | ROD BAR | 15 | D.U BEARING | | |
| 8 | O-RING | 16 | HEAD COVER | | |

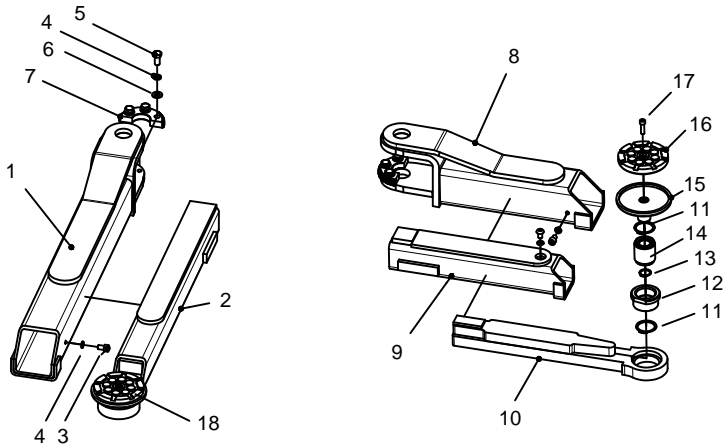

| NO | PARTS NAME | NO | PARTS NAME | NO | PARTS NAME |
|----|----------------------|----|-----------------------|----|-------------------|
| 1 | 1ST SECTION LONG ARM | 8 | 1ST SECTION SHORT ARM | 15 | PAD TRAY |
| 2 | 2ND SECTION LONG ARM | 9 | 2ND SECTION SHORT ARM | 16 | RUBBER PAD |
| 3 | WRENCH BOLT | 10 | 3RD SECTION SHORT ARM | 17 | WRENCH BOLT |
| 4 | SPRING WASHER | 11 | CIRCLIP | 18 | COMPLETE PAD UNIT |
| 5 | HEX NUT | 12 | PAD ADAPTER | | |
| 6 | FLAT WASHER | 13 | CIRCLIP | | |
| 7 | LARGE ARM LOCK GEAR | 14 | SCREW NUT | | |

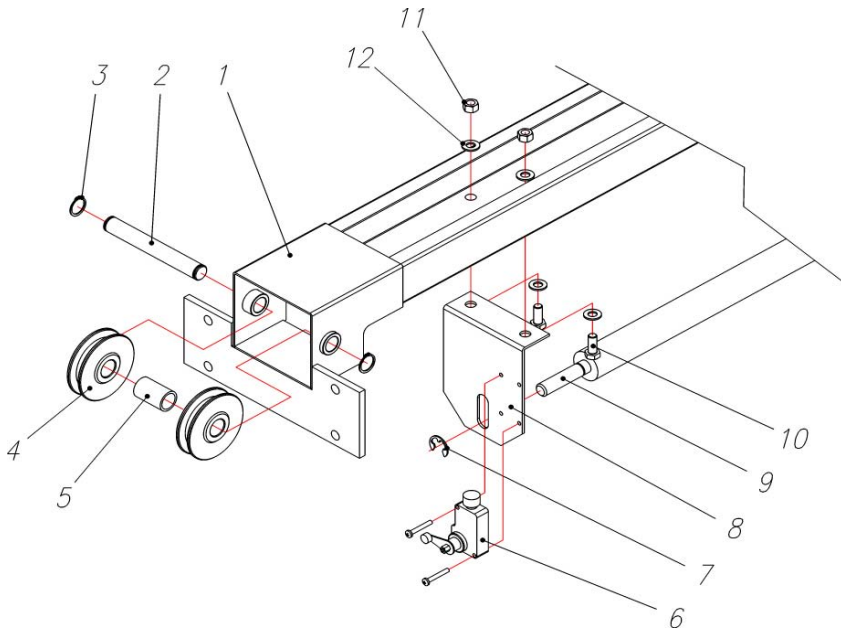

| NO | PARTS LIST | NO | PARTS LIST |
|----|--------------------|----|-----------------------|
| 1 | UPPER SUPPORT BEAM | 7 | E-RING |
| 2 | WIRE ROLLER SHAFT | 8 | LIMIT SWITCH FIXTURE |
| 3 | SNAP RING | 9 | UPPER LIMIT TOUCH BAR |
| 4 | WIRE ROLLER | 10 | HEXA BOLT |
| 5 | WIRE ROLLER SPACER | 11 | HEXA NUT |
| 6 | LIMIT SWITCH | 12 | FLAT WASHER |



CENTURY EQUIPMENT DISTRIBUTORS

415 MAIDSTONE TERRACE, UPPER HUTT,
5018 WELLINGTON, NEW ZEALAND

