

CENTURY»
AUTOMOTIVE EQUIPMENT

4000B

COMMERCIAL - 4000kg



CENTURY EQUIPMENT
54 Wainui Rd, Waiwhetu, Wellington
Phone: 04 567 1405 - Email: sales@centurydistributors.co.nz
www.centurydistributors.co.nz

CEN-4000B

Korean designed commercial grade lift for busy work-shops. Low maintenance and servicing costs with all the features for comfortable all day use.

- *2 Post clear-floor hoist. 4000KG lift rating.*
- *Electric control box with isolator switch*
- *Single point lock release and lowering.*
- *Double telescopic adjustable lifting feet.*
- *Minimum lift pad height 95mm - Maximum 140mm*
- *Includes 100mm ute / 4x4 adaptors*
- *3 stage front arms, 2 stage rear arms.*
- *Dual pre-stretched balancing cables.*
- *Automatic arm and carriage locks*
- *Top limit switch with padded bar*
- *Secondary carriage height limit*

- *4,000mm overall height
(Can be installed at 3,750mm)*
- *Max lifting height 1,940mm*
- *Drive-through width 2,516mm*
- *Standard colour ultramarine blue
Other colours available on order.*
- *220V or 415V options in stock*

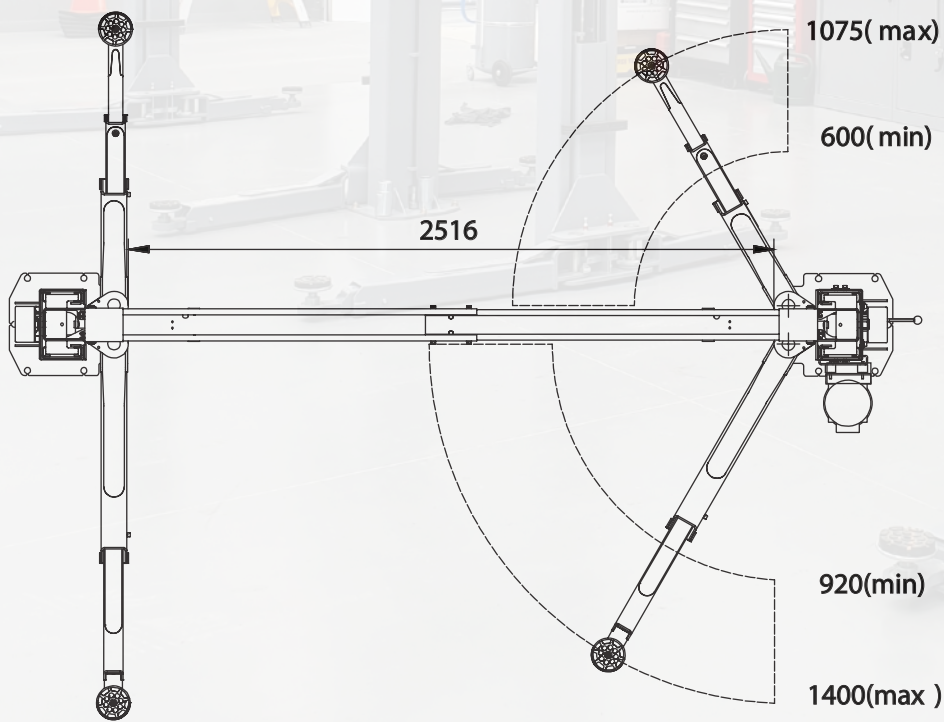
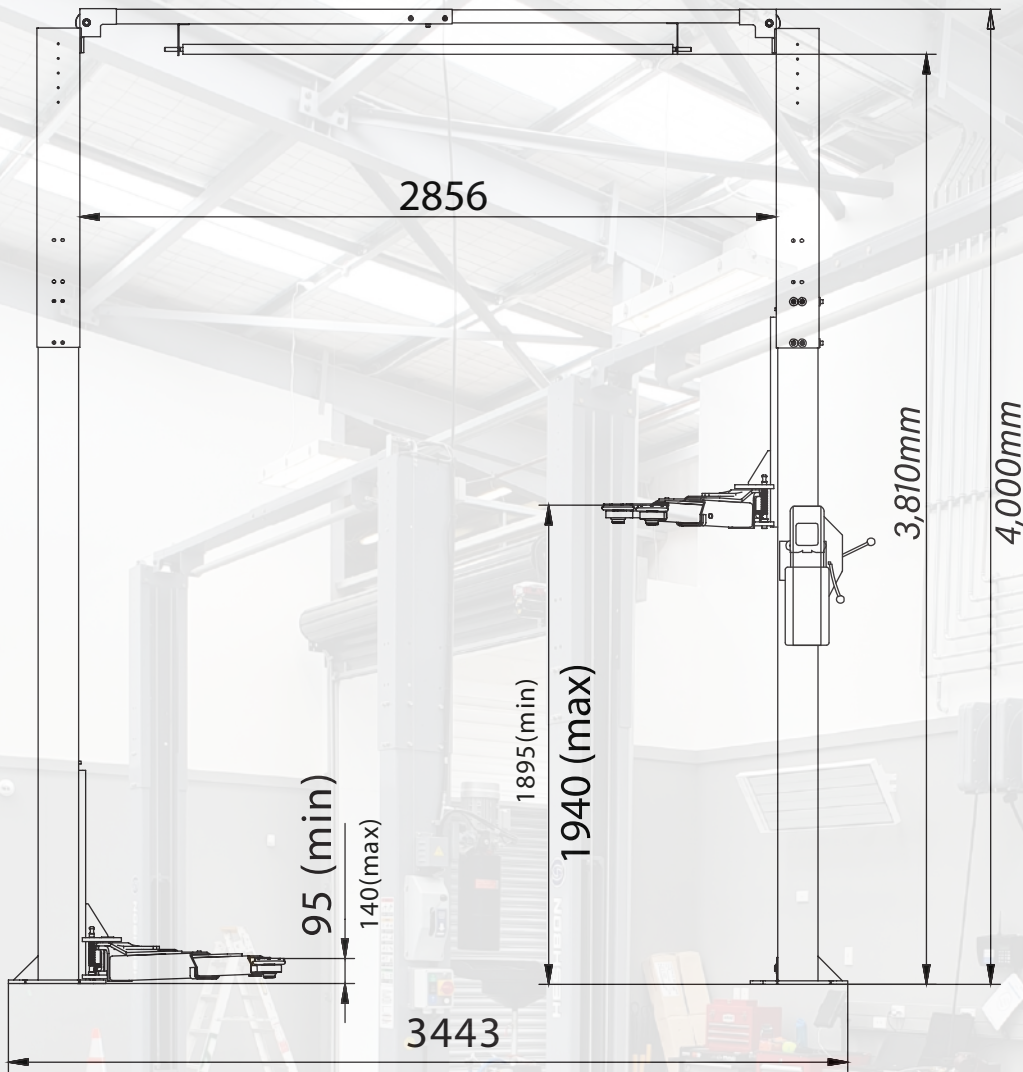

CENTURY

AUTOMOTIVE EQUIPMENT

- Tyre Changers
- Wheel Balancers
- 2 Post Lifts
- 4 Post Lifts
- Scissor Lifts
- Vehicle Storage

CENTURY EQUIPMENT

54 Wainui Rd, Waiwhetu, Wellington

Phone: 04 567 1405 - Email: sales@centurydistributors.co.nz

www.centurydistributors.co.nz